



Watch Live In Person or via YouTube at:

https://www.youtube.com/channel/UCBmloqX05cKAsHm_ggXCJIA

This meeting will be held at: **CITY OF HARDEEVILLE, COUNCIL CHAMBERS**
located at 205 Main St., SC 29927.

Citizens may sign up to speak in person at the Council Meeting before the regular meeting starts on the Public Comments Sign-in Sheet outside the Council Chambers Doors to address County Services and Operations. Presentations are limited to 3 minutes per person, and total input is limited to 30 minutes. Written comments must be submitted by 1 PM on the meeting date by emailing comments@jaspercountysc.gov (Ordinance #08-17)

To participate in a **Public Hearing for a specific agenda item**, email written public comments to comments@jaspercountysc.gov by 1:00 PM on Monday, June 1, 2026, or sign in on the colored Public Hearing Sign-in Sheet on the chair in the back of the Council Chambers before the meeting starts. Public Hearing comments are limited to 3 minutes per person.

Agenda support (e-packet) can be found at:

<https://www.jaspercountysc.gov/government/council/county-council-agendas-e-packets-and-minutes/>

For more information, call 843-717-3696. Instructions may also be found at the Jasper County website www.jaspercountysc.gov



JASPER COUNTY COUNCIL COUNCIL MEETING

Location: City of Hardeeville Council Chambers
205 Main St., Hardeeville, SC. 29927

Monday, June 1, 2026

AGENDA

4:00 PM: Budget Workshop

- 4PM – 4:30 PM -School District Budget Presentation—**Jatana Norris, Interim Finance Director, and Dr. Laura Hickson, Interim Superintendent.**
- 4:30 PM to 5:00 PM - FY 26/27 Budget by Kim Burgess

5:00 PM: Council Executive Session

➤ *Please silence your phones during the Meeting.*

1. Call the Council Meeting to Order by Vice Chairman Arzillo

Clerk's Report of Compliance with the Freedom of Information Act: In accordance with South Carolina Code of Laws, 1976, Section 30-4-80(d), as amended, notification of the meeting and the meeting agenda were posted at least 24 hours prior to the meeting on the County Council Building at a publicly accessible place, on the county website, and a copy of the agenda was provided to the local news media and all person's or organizations requesting notification.

2. Pledge of Allegiance and Invocation:

3. Approval of the Agenda:

4. Approval of the Consent Agenda:

Approval of the Consent Agenda passes all Consent Agenda Items. Consent Agenda Items are not considered separately unless a Councilmember requests it. In the event of such a request, the item is placed at the end of the Public Hearings, Ordinances, and Action Items.

CONSENT AGENDA ITEMS:

A) Approval of the Minutes 11.20.2026

This is the end of the Consent Agenda Items.

5. Executive Session SECTION 30-4-70.

(a) A public body may hold a meeting closed to the public for one or more of the following reasons:

(2) Discussion of negotiations incident to proposed contract arrangements and proposed

purchase or sale of property, the receipt of legal advice, where the legal advice related to pending, threatened, or potential claim or other matters covered by the attorney-client privilege, settlement of legal claims, or the position of the public agency in other adversary situations involving the assertion against the agency of a claim – (1) [Heather Rath – Consulting](#)
(4) [Conflict of Interest Waiver for Parker Poe related to Project Heat.](#)
(5) [Potential Purchase of Property – Tax Map # 063-26-02-001](#)

Any Executive Session Matter on Which Discussion Has Not Been Completed May Have Discussion Suspended for the Purpose of Beginning the Open Session at Its Scheduled Time, And Council May Return to Executive Session Discussion After the Conclusion of The Open Session Agenda Items.

Note: Please Be Advised, There May Be Votes Based on Items from the Executive Session.

6:00 PM: Regular Session

- Come out of Executive Session:
- Return to Open Session:

➤ 5.1. Council Action to be taken on items as discussed in Executive Session

Note: Council may act on any item appearing on the agenda, including items discussed in executive session.

6. PROCLAMATION:

A) [Vice Chairman Arzillo](#) – Presentation of a Proclamation from Jasper County Council to Dr. Lawrence E. Ford to Proclaim June 2026 as Forging Strong Fathers and Families Month.

7. Presentation:

[Kimberly Burgess](#) - Discussion regarding the status of the Jasper County 250 Committee.

8. CITIZEN COMMENTS:

Open Floor to the Public per Ordinance Number #08-17. Any citizen of the County may sign to speak in person at the Council Meeting (before the Council Meeting's 6:00 PM start time on the Sign-In Sheet on the Podium), to address the Council on matters pertaining to County Services and Operations. Presentations will be limited to three (3) minutes per person, and total public input will be limited to 30 MINUTES.

9. RESOLUTIONS

A) [Kimberly Burgess](#) – Consideration of Resolution [#R-2026-32](#) of Jasper County, SC. Approving The State Accommodations Tax Advisory Committee Recommendations And Authorizing The Award Of Funds For State Accommodations Tax Requests For The Fiscal Year Beginning July 1, 2026.

B) [Kimberly Burgess](#) – Consideration of Resolution [#R-2026-33](#) of Jasper County, SC. to Ratify An Additional Appropriation Of \$26,700 From Local Hospitality Tax Funds To The Jasper County 250 Committee.

C) **Kimberly Burgess** – Consideration of Resolution [#R-2026-34](#) of Jasper County, SC to Ratify The Purchase of Playground Equipment and Playground Surface at Gray’s Community Center Not to Exceed \$112,000.

E) **Kimberly Burgess** – Consideration of Resolution [#R-2026-36](#) of Jasper County, SC. Authorizing The Award Of Funds For Requests For Local Accommodations And Hospitality Taxes For Fiscal Year Beginning July 1, 2026.

F) **Keith Horton, Clerk of Court and Jessica Davis** - Consideration of Resolution [#R-2026-26](#) a Resolution of Jasper County, South Carolina, Approving the Establishment of a Rollover Bank Account for Unencumbered Title IV-D Child Support Funds Known as Unit Cost Reimbursement Funds. *(Item was tabled at the 05.04.2026 meeting)*

G) **Wanda Giles** - Consideration of Resolution [#R-2026-29](#) of Jasper County, SC. for the Appointment of Mr. James G. Williams as the Jasper County Council of an LCOG Representative for the At-Large Position to the Lowcountry Council of Governments Board. *(Item was tabled at the 05.18.2026 meeting)*

10. PUBLIC HEARINGS, ORDINANCES, AND ACTION ITEMS

A) **Kimberly Burgess** – Consideration of approval of the **2nd Reading** of Ordinance [# O-2026-18](#) to provide for the levy of tax for public purposes in Jasper County for the fiscal year beginning July 1st, 2026 and ending June 30th 2027 and to make appropriations for said purposes; to adopt and approve the Jasper County capital and operations budget for fiscal year 2026-2027, to adopt and approve the Jasper County School District capital and operations budget for fiscal year 2026–2027; to provide for the levy of taxation for fiscal year 2026–2027; to limit the disbursements by the county treasurer to those appropriated by law; to provide that expenditures not exceed appropriations; to authorize tax anticipation notes; to make authorization of certain transfers; to provide for additional appropriations and borrowing; to codify Jasper County rates and fees; to provide for lapsing funds and continuing appropriations for subsequent years; to require certain agencies and departments to file accountings; to require the treasurer to sign general fund checks; to provide special rules for travel and training disbursements; to provide for travel reimbursements; to provide compliance with act no. 317 of 1990; to provide certain benefits to council members; to provide for county commission and committee stipends; to provide for jury mileage; to adopt property values; and to provide for effective date of this ordinance, and matters related thereto. *(1st reading 05.18.2026 by Title Only)*

B) **Kimberly Burgess** – Consideration of the **1st Reading** by **TITLE ONLY** of an Ordinance to Provide for the Issuance and Sale of not Exceeding Two Million Dollars (\$2,000,000) Aggregate Principal Amount of General Obligation Bonds of Jasper County, South Carolina in one or more series, to Prescribe the Purposes for which the Proceeds Shall Be Expended, to Provide for the Payment Thereof, and to Provide for Other Matters Related Thereto.

C) **Hunter Smiley** - Consideration of **1st Reading** of an Ordinance to amend the Official Zoning Map of Jasper County so as to transfer a property located along Hoota Woods Plantation Road, bearing Jasper County Tax Map Number 052-00-10-013 consisting of 312.43 acres from the Residential Zone and Rural Preservation Zone to the Rural Preservation Zone on the Jasper County Official Zoning Map.

D) **Eric Larson** - Consideration of awarding bid to Lorick Office Products to upfit furniture for the Development Services Department and Code Enforcement Department, at a cost of \$52,983.33 and authorize the Administrator to finalize the purchase.

E) **Keith Horton, Clerk of Court and Jessica Davis** – Consideration of the Request to Approve the Purchase of two X-ray Machines—one for the Courthouse and one for the Administrative Building—for a total of two machines, to be funded from this new line item. *(Item was tabled at the 05.04.2026 meeting)*

11. Administrator’s Report:

12. Councilmember Comments and Discussion

13. Adjournment:

Special Accommodations Available Upon Request to Individuals with Disabilities, please contact the Jasper County ADA & Civil Rights Coordinator, ***Tisha Williams*** in person at 358 Third Avenue, Ridgeland, South Carolina, by telephone at ***(843) 717-3690*** or via email at [***jadministrator@jaspercourtysc.gov***](mailto:jadministrator@jaspercourtysc.gov) no later than 48 hours prior to the scheduled meeting.

AGENDA

ITEM:

- 4PM – 4:30 PM -School District Budget Presentation—**Jatana Norris, Interim Finance Director, and Dr. Laura Hickson, Interim Superintendent.**
- 4:30 PM to 5:00 PM - FY 26/27 Budget by Kim Burgess

****No information for these items were provided for inclusion into the agenda e-packet****

CONSENT AGENDA

ITEM # 4A:

MINUTES



JASPER COUNTY COUNCIL COUNCIL RETREAT

Jasper County Clementa C. Pinckney Government Bldg.
358 3rd Avenue Ridgeland, SC
29936

Thursday, November 20, 2025
Minutes

Officials Present: Vice Chairman Joey Rowell, Councilman Chris VanGeison and Councilman Gene Ceccarelli
Absent: Chairman John Kemp and Councilman Joseph Arzillo,

Staff Present: County Administrator Andrew Fulghum, Clerk to Council Wanda Giles, Kimberly Burgess, Lisa Wagner, James Iwanicki, Chief Russell Wells, Leonard Sansone and Videographer Jonathan Dunham.

Call to Order of the Jasper County Council Retreat:

The meeting was brought to order. The Report of Compliance with the Freedom of Information Act was listed on the agenda document as follows: In compliance with the Freedom of Information Act, notice of meetings and agendas were posted and furnished to all news media and persons requesting notification. In accordance with the Freedom of Information Act the electronic and print media were notified.

Mr. Fulghum opened the retreat with a discussion on strategic planning. Strategic planning was discussed as a work plan for the county to provide a vision and mission statement, goals, with a focus on organizational efforts, and guide decision-making. The County's Projects and Comprehensive Plan was discussed. The proposal to update the Comprehensive Plan in the future was also discussed. A quarterly review of current the Budget was discussed and presented. As of the quarterly financial statement of 09.30.2025 the revenues, expenditures, transparency, and software upgrades were discussed. Revenues including a discussion of upcoming fiscal budget was discussed between Council and Staff.

The Engineering and Capital Improvement Projects were also discussed and reviewed. The active projects including 252 Russell St. The new IT building, located at 252 Russell Street, was noted had been completed under budget. The architectural phase of the Coosawhatchie Fire Station and the Tillman Fire Station replacement were also discussed. The acquisition of new dump trucks and roll off trucks for the Engineering Division to handle solid waste internally was also discussed for operational efficiency. A proposal was made to create an as needed service contract for trades like plumbing and carpentry for projects up to \$25,000 to bypass lengthy formal bidding processes for minor repairs. The Council also discussed using pre-engineered metal buildings such as steel structures for future firehouses and community centers to reduce cost as significantly compared to traditional block construction. The County grants were discussed in areas such as the Airport, Public Safety and Infrastructure.

The following department updates were provided for Airport Operations, Planning and Building Services, Parks and Recreation, Emergency Services, IT and GIS:

Airport Operations were discussed regarding revenue growth, strategic goals and exploring becoming a reliever airport to capture more general aviation traffic.

Planning and Building Services were discussed regarding the Euhaw Overlay District, residential development and the Abbey Glen drainage.

Parks and Recreation were discussed regarding facility improvements such as scoreboards, fencing, and floating docks at Sergeant Jasper park. Community programs were discussed, along with the disc golf course at Sergeant Jasper Park.

Emergency Services was discussed in relation to fleet updates. The arrival of the new fire engines that have been received was noted. A public safety shelter was discussed with plans that are under way to use Polaris tech as a public safety shelter for Jasper County.

Informational Technology (IT) and the GIS system were discussed in relation to infrastructure upgrades to the county e-mail server being 98% complete. The GIS server update was expected by December. Plans were moving forward to digitize records for HR and other departments to save physical storage space.

Council members expressed appreciation for staff's hard work and noted the unprecedented growth that was facing Jasper County, and how that would be a focus in the future. It was mentioned that an upcoming focus would be on the upcoming January budget process and the goal of potentially reducing millage following reassessments. The Council Retreat adjourned.

For more information on this meeting, please visit our YouTube Channel for the video at https://www.youtube.com/channel/UCBmloqX05cKAsHm_ggXCJIA. Closed captions are also available for all of our County Council videos. Just click the "**CC**" button to follow along.

Respectfully submitted:

Wanda H. Giles
Clerk to Council

Joseph Arzillo, Vice Chairman

AGENDA

ITEM # 6:

PROCLAMATION

State of South Carolina

Jasper County

Proclamation 2026

WHEREAS, fathers serve as the foundational architects in forging strong and resilient families, providing unwavering love, steadfast guidance, and consistent support that shape the character of their children and the future of our communities; and

WHEREAS, the profound influence of engaged fathers on their children's development is transformative, as they impart core values, build emotional resilience, and equip young people to thrive socially, academically, and personally; and

WHEREAS, the South Carolina Center for Fathers and Families, established in 2002, demonstrated a remarkable increase in impact annually by serving thousands of fathers and children statewide; and

WHEREAS, through its longstanding and productive collaboration with the South Carolina Department of Social Services, along with numerous state, local, and private partners, the Center has expanded its footprint by strategically opening new offices, now operating fifteen hub locations that deliver services across all 46 counties of South Carolina; and

WHEREAS, the Center has strengthened its Father365 statewide network of regional affiliates, enabling thousands of fathers to access high-quality programming in parenting, healthy relationships, economic mobility, jobs training, legal navigation, and mental health support; and

WHEREAS, when fathers actively engage in forging deep and purposeful relationships with their children, these families experience powerful outcomes, including more income earned by program participants, more child support paid, and more saved in incarceration costs, while the Center continues to serve as a national model for innovative and effective fatherhood initiatives;

NOW, THEREFORE, we, the County Council of Jasper County, South Carolina, do hereby proclaim June 2026 as

FORGING STRONG FATHERS AND FAMILIES MONTH

throughout the county and encourage all citizens in our county to honor the fathers and father figures in their lives, support programs that strengthen men and families, and actively participate in forging resilient families that will sustain our communities for generations to come.

(Seal)

Joseph Arzillo
Jasper County Vice Chairman



**SOUTH CAROLINA CENTER
FOR FATHERS AND FAMILIES**

A Ministry of the Sisters of Charity Health System



Honorable County Council

Re: Request to Proclaim June 2026 as “Forging Strong Fathers and Families Month”

Dear Council Members:

On behalf of the thousands of fathers and children we serve across all 46 counties, I am writing to invite your council to join a growing statewide campaign by officially proclaiming **June 2026** as **Forging Strong Fathers and Families Month**.

We have attached a ready-to-adopt proclamation that mirrors language successfully used by the Governor and numerous municipalities where we serve families. Adopting this proclamation is a powerful, zero-cost way for your Council to publicly affirm the foundational role fathers play in building resilient families and thriving communities right here in your county.

Why this matters — especially in your county

Fathers are essential architects of family stability. When fathers are engaged, children experience better academic outcomes, stronger emotional resilience, fewer behavioral challenges, and brighter economic futures. Communities see higher child-support compliance, lower incarceration rates, and measurable reductions in the societal costs of father absence.

Your county already benefits from our statewide network. Through our Hub & Spoke model and the Father365 network of five regional affiliates, high-quality programming reaches every corner of South Carolina — including the families of your county. Services are delivered locally through 15 hub offices plus remote and quarterly spoke services.

2025 Impact Highlights (from the included Annual Impact Report) demonstrate the transformative results we achieve together:

- 3,409 fathers served statewide — 15% more than 2024 and the third consecutive year of double-digit growth — achieving 192% of our annual SCDSS goals.
- These fathers directly impacted more than 3,800 children.
- Program participants generated \$416,815 in new earned income.
- Fathers paid \$842,391 in child support.
- Taxpayers saved \$1,554,300 in avoided incarceration costs.
- Combined economic ripple effect estimated at a potential \$115.8 million contribution to South Carolina’s economy.

By proclaiming June 2026 as Forging Strong Fathers and Families Month, your Council will honor the fathers and father figures who already strengthen your county every day, encourage residents to participate in local Father365 programming, community events such as FatherFests

South Carolina Center for Fathers and Families

2711 Middleburg Drive, Suite 111 · Columbia, SC 29204

www.scfathersandfamilies.com

and “ThanksDaddy” meal distributions, and family-strengthening initiatives, and join the Governor and other municipalities that issued similar proclamations in each year.

Please contact Dr. Lawrence Ford, our Director of Communications, to discuss next steps. He and his team will work with you to schedule the presentation and to select representatives to attend the council meeting. Reach Dr. Ford directly at (803) 807-1740 and by email at lford@scfathersandfamilies.com.

Together, we can ensure that every child in your county grows up with the love, guidance, and stability that engaged fathers provide. Thank you for your continued leadership and for considering this meaningful proclamation.

Happy Fathers’ Day...every day!

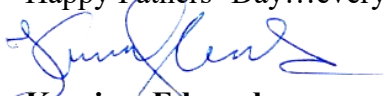
Karriem Edwards
President



SOUTH CAROLINA CENTER
FOR FATHERS AND FAMILIES

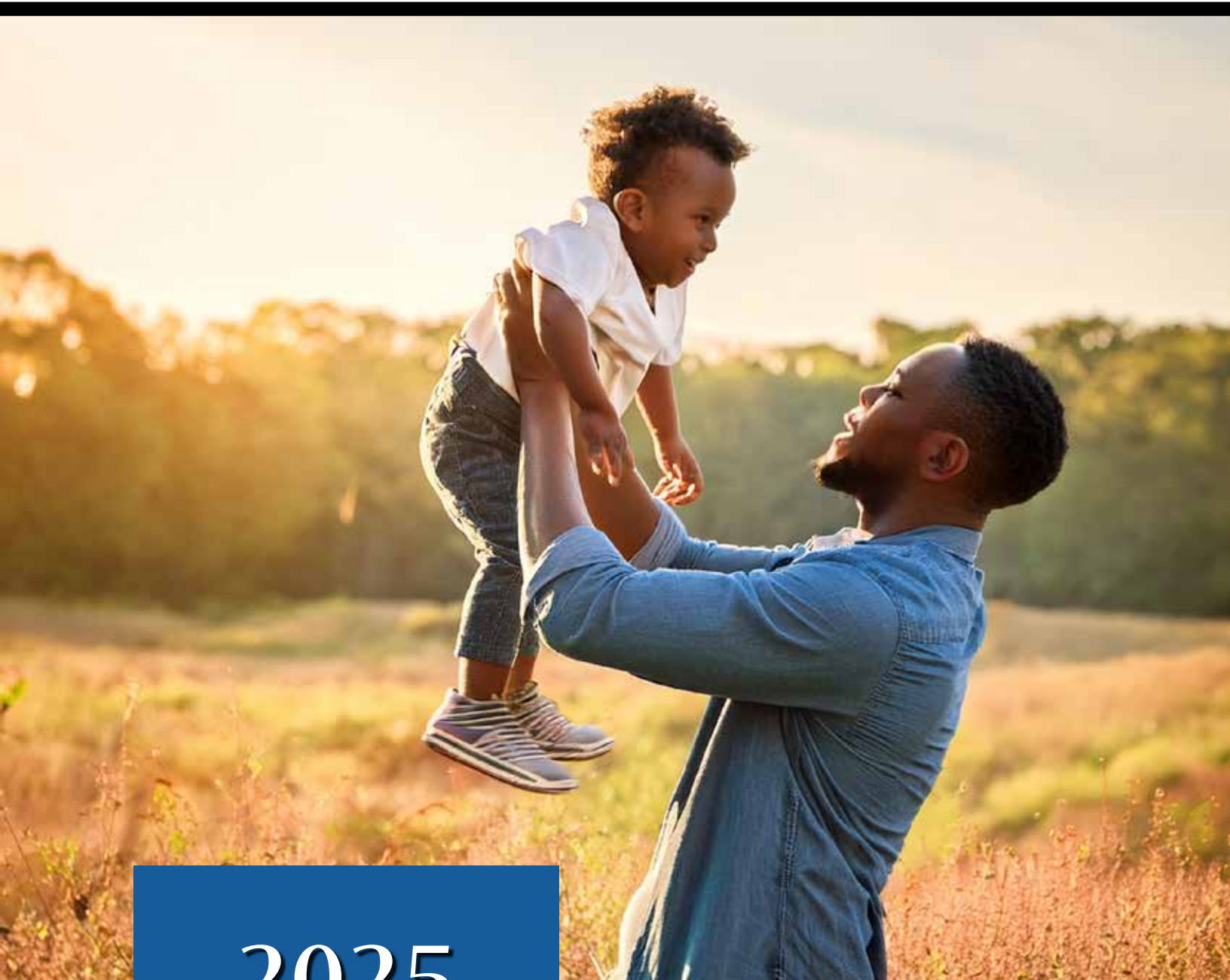

2025 IMPACT REPORT

Elevate Fatherhood

Helping Fathers Become Great Dads!

A Ministry of the Sisters of Charity Health System



WHO WE ARE

At the South Carolina Center for Fathers and Families (SCCFF), we're dedicated to uplifting fathers navigating economic hardships, societal hurdles, and personal struggles throughout South Carolina's 46 counties. Our core purpose is to equip these dads with essential tools and guidance, helping them step up as outstanding parents and integral figures in their kids' worlds. An involved father can truly turn the tide on countless family issues we see today. We're building toward a world where kids and households don't merely get by—they flourish—through fair and targeted support for fathers overcoming diverse obstacles.

Fresh data from the Annie E. Casey Foundation highlights an encouraging shift: fewer South Carolina children are in single-parent households. In the most recent reporting year, that figure dropped to 350,000 from 382,000 the year before, signaling a rise in stable, two-parent environments.

Backed by partnerships with government and private organizations, SCCFF is steadily boosting our efficiency and life-changing influence. Year after year, we sharpen our strategies and actions, always zeroing in on connecting the next dad and his family.

Key 2025 Milestones

- Served more than 3,400 fathers.
- Achieved 192% of our SCDSS goals.
- \$416,815 of new income for dads who got jobs through our program.
- Awarded a new \$6.25 million fatherhood grant from HHS.
- Opened up new offices in Beaufort, Orangeburg, and Aiken.
- Engaged SC ETV in collaborative fatherhood curriculum overhaul.
- Received 20 “Elevate Fatherhood Month” proclamations from the governor and 19 municipalities.

Robert's Persistence

Robert enrolled in drug court, as well as parenting classes at A Father's Place (AFP). He showed persistent dedication, attending sessions faithfully, and applying the tools he gained. Over time, his hard work paid off. Robert secured stable employment, found safe and reliable housing, and passed every required drug test. On the day he graduated from AFP, Robert was reunited with all his children.



OVER 3,800 KIDS IMPACTED!



MY BIGGEST FAN



“When you teach your son, you teach your son’s son.” — The Talmud

I only played one year of football, and that was in third grade. I was the QB. From what my dad tells me, I could’ve been the next Peyton Manning. My parents were divorced, and I lived with my mother in Charleston while my father lived in Columbia. So, it wasn’t often he was able to make it to my games, but he was my biggest fan. I can still remember the feeling during one Wednesday night game when I came out of the huddle and looked over and surprisingly saw him there. He waved. I don’t remember what happened next but I do remember busting out for what felt like a 50 yard touchdown run, and my father pacing me down the sidelines as I ran my 8 year old heart out. I’ll never forget that moment.

There’s a saying from The Talmud that “when you teach your son, you teach your son’s son.” The presence of a father doesn’t just result in touchdowns. It has generational impact long after the last quarter is played, the last base is crossed, the last cheer is cheered. That’s why the work we do here at the South Carolina Center for Fathers and Families is absolutely critical. The societal, cultural, and even economic impact of engaged and healthy fathers is immense. I love the change we are seeing in the lives of fathers from Horry County all the way down the coast of the low

country, from the midlands to the hills of Greenville County.

To that end, in 2025 we saw:

- 192% of our goal to reach more dads
- Over 3,400 fathers served
- Award of new federal fatherhood grant

While the numbers speak to our impact, the need for what we do continues to grow. That’s why 2025 has been a year of planning for the next 3-5 years. As an organization, we launched a revamp of our strategic plan. The need to diversify our funding sources, strengthen our already amazing relationships with local organizations, and package our content for broader audiences are clear themes of where we head as we move into 2026. The need is great, but our organization and our partner organizations stand ready for the challenge. Cheers to a successful 2025 and what will be a pivotal and important 2026.

Happy Father’s Day,

TJ Clayton, Board Chairman

GIVING OUR KIDS WINGS

I've always been captivated by the story of the Wright brothers — two bicycle mechanics from Ohio who dared to dream of conquering the skies. As a young boy, I pored over accounts of their relentless experiments on the windswept dunes of Kitty Hawk, facing failure after failure, skepticism from the world, and the sheer impossibility of giving wings to humankind. Yet, through ingenuity, perseverance, and an unyielding belief in what could be, they achieved the first powered flight in 1903, forever changing the course of history. That tale of turning the improbable into reality has inspired me throughout my life, reminding me that true progress often emerges from the toughest trials.

In many ways, 2025 echoed that spirit for us at the South Carolina Center for Fathers and Families. It tested us in every way. With uncertain funding, a constantly shifting landscape, and little room for error, we faced real challenges. Yet amid the noise, we remained steadfast in our commitment to what matters most: showing up for dads.

That focus paid off. We served 15% more fathers than last year, marking our third consecutive year of double-digit growth — driven by smarter, more efficient service to dads in remote communities. Even more important, we strengthened the quality of that service. Every father now receives a PHQ-9 mental health assessment, flexible

program timelines that respect real life, and new opportunities to build community through Father Fellows, Father Fests, and our continued “Thanks Daddy” meal distributions. None of this works without trust — and we are deeply grateful to the fathers who place that trust in us every day.

At the same time, we invested in the people who make this mission possible. As fathers' needs evolved, so did our staff. In 2025, we doubled down on professional development, self-care, and leadership — because strong dads require strong teams.

We owe tremendous thanks to our leadership team, who focused on serving more fathers as efficiently as possible while strengthening their own skills and fostering greater collaboration.

What we accomplished in 2025 is a story of resilience, smart growth, and forward motion — proof that even in a difficult year, meaningful progress is not only possible, but inevitable when we work together. More dads lifted up so that they can give wings to their children.

Happy Fathers' Day! Every Day!



Karriem Edwards

“ We are deeply grateful to the fathers who place that trust in us every day.



OUR WORK



The South Carolina Center for Fathers and Families (SCCFF) stands as the nation's leading statewide network of fatherhood programs. With robust support from local, state, and federal grants, along with premier foundations, corporations, and individual donors, SCCFF spearheads the delivery of critical funding, innovative programming, and expert technical assistance to five distinguished fatherhood affiliates.

- **A Father's Place** leads service delivery across eleven coastal counties, transforming lives through six strategically placed hubs.
- **Man 2 Man** empowers fathers in six Pee Dee counties, reaching families through three dynamic hubs.
- **Midlands Fatherhood Coalition** is a catalyst for change in sixteen Midlands counties, providing comprehensive services through five robust hubs.
- **A Father's Way** delivers vital support to fathers in four northwest counties, operating from two dedicated hubs.
- **Upstate Fatherhood Coalition** drives measurable progress for fathers in nine Upstate counties through three centers of excellence.

Our fifteen hub offices deliver comprehensive, on-site **programming**, featuring group and individual case management and complimentary educational programs that empower men in the following areas of parenting, healthy relationships, economic mobility, and physical and mental health.

Our **services** include decisive legal guidance for child support, custody, paternity, and visitation. Intervention specialists equip fathers to assess their situations, understand their rights, and confidently navigate social service and family court systems. We stand with fathers in court, supporting them in their journey of reconnection with their children and full engagement in parenting — fostering stronger, thriving families.

Beyond fatherhood programs, SCCFF delivered a five-year proactive program for the next generation through its **Ready4Life** initiative for high school boys. Ready4Life delivers a rigorous curriculum that empowers young men to make informed, responsible choices before adulthood, with an emphasis on family planning and responsible parenthood. The Reality Check curriculum has been widely implemented in schools, community organizations, and athletic teams.

SCCFF launched **Father365.com**, a comprehensive, father-focused website that offers vital information and resources. Through Father365.com, fathers statewide can easily connect with our expert staff, access full-service hubs and outreach spokes, and benefit from programs and services tailored for every participant.



CODY: A NEW BEGINNING

Cody Wahl is an extraordinary father whose resilience, discipline, and steadfast love have become a beacon of hope to other fathers. When Cody enrolled at our regional partner Midlands Fatherhood Coalition, his son was in foster care, and Cody made a courageous decision to reunite his family. Despite facing legal battles, setbacks, and emotional hardship, Cody's unwavering spirit and hope lit the way forward.

After months of unwavering commitment — attending every session, meeting challenging court requirements, and focusing on personal growth — Cody appeared in court and was granted temporary custody of his son. The judge recognized not just Cody's progress, but his transformation, opening the door to reunification and a new beginning filled with hope.

The day Cody picked up his son was a moment overflowing with relief, gratitude, and pure joy. He gave thanks for this second chance, but also for the unwavering support of his Intervention Specialist, Jarell Rose, whose steadfast belief in Cody's potential saw him through. On this life-changing day, hope and faith triumphed.

Cody's story stands as a powerful testament to the extraordinary change that is possible when a father stays focused on his future. His strength, perseverance, and humility have brought healing and inspired others to believe in the power of redemption and love.

With support, Cody has worked hard to elevate his role in his son's life, saving himself, his family, and his community from emotional and economic burdens he used to carry. He is now filled with hope, purpose, and promise.

Fatherhood Numbers at a Glance

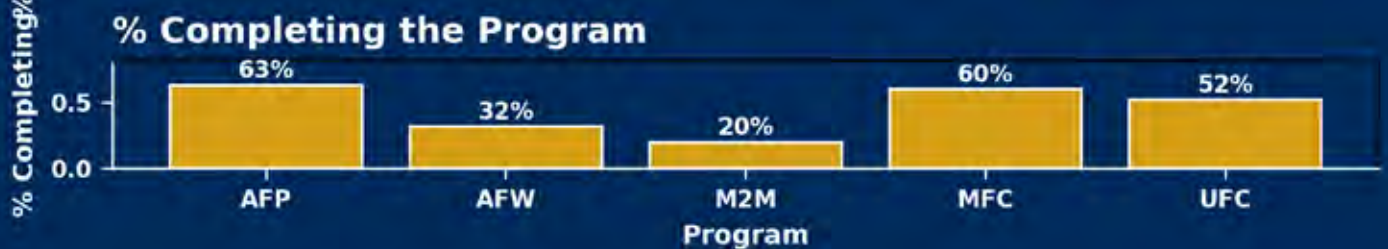
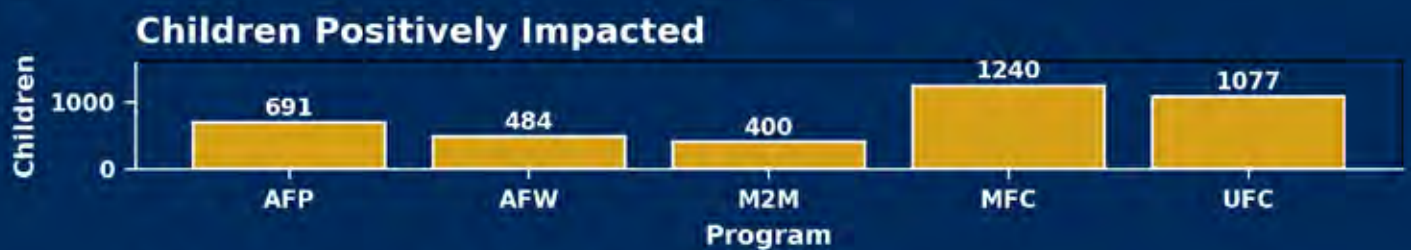
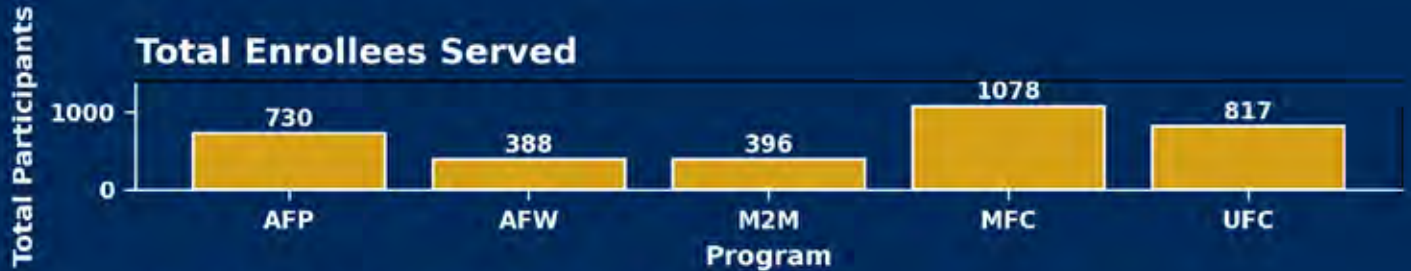

A photograph of a man with a beard and short brown hair, wearing a blue t-shirt, holding a young child with light brown hair in a light blue shirt. The man is looking up at the child with a smile. The background is plain white.

PROGRAM IMPACT

3,409 = Total Dads Served in 2025

2,008 = Total Program Enrollees

1,401 = Total Service Enrollees

182 = Average Days in Program

\$416,815 = New Income for Dads in Program

\$842,391 = Amount of Child Support Paid

\$1,554,300 = Amount Saved in Incarceration

\$115.8 million = Potential Contribution to the State

We deeply appreciate the collaboration within our statewide network and look forward to strengthening our partnership as we work to elevate fathers and their families. Our collective efforts are already helping more dads and families thrive across our state, but we know that many more still need our support to help their children succeed. By empowering fathers to become more engaged every day, we can help families overcome challenges and barriers that stand in their way. Together, we will continue making a profound difference for fathers, their families, and communities throughout South Carolina and beyond.

Lifted up.



The South Carolina Center for Fathers and Families is a non-profit ministry established by the Sisters of Charity Foundation of South Carolina in 2002. We provide educational, medical, legal, and career resources for fathers to reconnect with their families and become great dads, in partnership with five regional affiliates through more than 15 offices statewide.

For more information about our work, visit www.scfathersandfamilies.com or call us at 803.227.8800.

AGENDA

ITEM # 7:

PRESENTATION

**STATE OF SOUTH CAROLINA
JASPER COUNTY**

RESOLUTION NUMBER R-2023-04

RESOLUTION OF JASPER COUNTY COUNCIL

**SUPPORTING THE SOUTH CAROLINA AMERICAN REVOLUTION
SESTERCENTENNIAL COMMISSION
AND
RECOGNIZING AND APPROVING THE JASPER COUNTY 250
COMMITTEE**

WHEREAS, South Carolina created the South Carolina American Revolution Sestercentennial Commission (250th Anniversary Commission also known as SC250); and

WHEREAS, the mission of the SC250 Commission is to celebrate and promote South Carolina's role in the American Revolution by educating, engaging, and inspiring South Carolinians and visitors; and

WHEREAS, the SC 250 Commission is seeking partnerships with Counties and municipalities to further its mission; and

WHEREAS, this partnership will be formed by creating a local committee called the Jasper County 250 Committee; and

WHEREAS, the Jasper County 250 Committee will focus on important events, people, and places during the Revolutionary Era with Jasper County to promote, observe and celebrate Jasper County's role in the American Revolution by educating, engaging, and inspiring South Carolinians and visitors; and

WHEREAS, local projects (i.e. creating visitable historical sites to attract tourists, supporting celebrations, restoring local history markers, rebuilding local historical infrastructure, etc.) will enhance historical tourism opportunities; and

WHEREAS, Jasper County Council, pursuant to Section 2-77(b) of the Jasper County Code of Ordinances may by resolution appoint a special committee to assist the County, which shall also contain a termination date;

NOW THEREFORE BE IT RESOLVED, that the Jasper County Council:

1. Hereby recognizes the Jasper County 250 Committee as its official special committee with the following members:

Smittie Cooler
 David Huguenin
 Rita Livingston
 Milton Woods
 Patricia DuPont
 Cathy DeCourcy
 Tommy Rhodes
 John Kemp
 Valerie Guzman
 Devonte Genwright
 Peach Morrison
 Sharon Shay
 Bill Olendorff
 Eddie Stanley
 Ron Roth

2. Will partner with the South Carolina American Revolution Sestercentennial Commission (SC250).
3. Will support initiatives of the SC250 Commission.

4. Will support the Jasper County 250 Committee in its local efforts to educate, engage, and inspire South Carolinians and our visitors, thereby enhancing historical tourism opportunities in Jasper County.

5. The termination date of the Jasper County 250 Committee shall be 30 days after the South Carolina American Revolution Sestercentennial Commission completes its stated mission, unless otherwise altered or amended by subsequent resolution of the Jasper County Council.

This Resolution No. R-2023-04 made this 17th day of April, 2023, and effective immediately.



L. Martin Sauls, IV
Chairman

ATTEST:



Wanda Simmons
Clerk to Council

Reviewed for form and craftsmanship by the Jasper County Attorney.

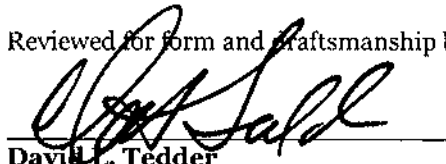

David L. Tedder

4-17-2023
Date

ACCOMMODATIONS TAX REQUEST APPLICATION

Jasper County, South Carolina

ACCOMMODATIONS TAX FUNDS REQUEST APPLICATION

Requesting (please check mark): State or Local

Date: April 10, 2026

Total Project Costs: \$36,600

Total Amount Requested: \$36,600

A. PROJECT NAME: Jasper County Revolutionary War Interpretation & Visitor Center

B. ORGANIZATION: Jasper County 250

Sponsor Name: _____ Title: _____

Sponsor Address: _____

Sponsor Phone: _____

Contact Name: Earl Cooler, JR Title: Chairman

Contact Address: 1860 Tickton Hall Rd, Ridgeland, SC 29936

Contact Phone: 843-226-0221

For Office Use Only

Date Received: _____ Time Received: _____ By: _____

DESCRIPTION OF PROJECT:

1. General Description:

This project establishes a public-facing Revolutionary War interpretation center designed to attract heritage tourism to Jasper County.

The facility will present professionally developed, map-based exhibits illustrating military movement, terrain, and local historical significance with the Southern Lowcountry.

This project fills recognized gap between Charleston and Savannah by creating a destination focused on Revolutionary War landscape interpretation tied specifically to Jasper County geography.

2. Impact on or benefit to tourism (if required under the law).

The project is designed as a tourism-generating asset. Target audiences include heritage tourists, genealogists, and visitors to Hilton Head and Savannah.

Projected annual visitation is estimated between 2,000 to 5,000 visitors in initial phases, with growth expected as regional awareness increases.

This project enhances Jasper County's tourism offerings by introducing a permanent interpretive experience focused on Revolutionary War history.

It supports extended visitor stays, repeat visitation, and cross-promotion with regional tourism destinations.

3. Duration of project: Start Date: July 1, 2026 Completion Date: July 1, 2027

4. Permits required (if any): _____

5. Additional Comments:

B. FUNDING:

1. Source of funds: Jasper ATAX funding _____

2. Have you requested funding from other sources or organizations for this project? No

If yes, please list sources and amounts.

3. Contributions to the project by the sponsoring organization:

Volunteer hours for implementation, interpretation and maintaining presence at center.

C. FINANCIAL INFORMATION:

1. A line-item budget of the project (sample below.)

See attached spreadsheet.

2. Most recent fiscal year balance sheet and profit and loss accounting statement.

D. FINANCIAL GUARANTEES:

Provide a copy of official minutes where in the sponsoring organization approves the

project and commits the organization to financial responsibility for carrying it out to the stage of completion contemplated in the application, should funding be approved.

E. PRIOR RECIPIENT'S REPORT (If you received prior ATAX funds): (Attach additional sheets, if needed):

1. How did you use the funds?

2. What impact did this have on the community or benefit tourism? Describe how tourism statistics were captured.

3. Provide the previous two years and current budgets.

4. Include the **total annual funding** received each year that you applied.

Signature: _____ Date: _____

APPLICATION FINAL CHECKLIST

(Complete and return this list with the application)

- The application is being filed by the deadline as indicated in this application packet.
- We have reviewed and followed the application guidelines.
- We are submitting one (1) complete hard copy of the application and one (1) complete electronic copy of the application.
- We will be prepared to make a verbal presentation to the Committee and answer questions when we are scheduled to do so.
- We did not bind the application (NO BOOKS or BINDERS).**

Jasper County ATAX State Application

CATEGORY	AMOUNT REQUESTED	AMOUNT APPROVED	AMOUNT EXPENDED	AMOUNT REIMBURSED TO COUNTY
Exhibit Panels Large format printed panels (20 units)	\$ 5,000.00			
Content Development Design/layout of panels	\$ 4,800.00			
Mounting System Frames, hardware and installation	\$ 3,500.00			
Map Reproductions High resolution historical map prints	\$ 4,500.00			
Lighting Exhibit focused track lighting	\$ 2,500.00			
Signage Exterior and interior visitor signage	\$ 3,000.00			
Website & Marketing	\$ 10,000.00			
Contingency	\$ 3,300.00			
TOTAL Requested	\$ 36,600.00			
TOTAL Requested	\$ 36,600.00			

ACCOMMODATIONS TAX REQUEST APPLICATION Jasper County, South Carolina

ACCOMMODATIONS TAX FUNDS REQUEST APPLICATION

Requesting (please check mark): Local X

Date: April 10, 2026 Total Project Costs: \$65,100 Total Amount Requested: \$65,100

A. PROJECT NAME: Jasper County Revolutionary War Interpretation & Visitor Center

B. ORGANIZATION: Jasper County 250

Sponsor Name: _____ Title: _____

Sponsor Address: _____

Sponsor Phone: _____

Contact Name: Earl Cooler, JR Title: Chairman

Contact Address: 1860 Tickton Hall Rd, Ridgeland, SC 29936

Contact Phone: 843-226-0221

For Office Use Only

Date Received: _____ Time Received: _____ By: _____

project and commits the organization to financial responsibility for carrying it out to the stage of completion contemplated in the application, should funding be approved.

E. PRIOR RECIPIENT'S REPORT (If you received prior ATAX funds): (Attach additional sheets, if needed):

1. How did you use the funds?

2. What impact did this have on the community or benefit tourism? Describe how tourism statistics were captured.

3. Provide the previous two years and current budgets.

4. Include the **total annual funding** received each year that you applied.

Jasper County ATAX Local Application

CATEGORY	AMOUNT REQUESTED	AMOUNT APPROVED	AMOUNT EXPENDED	AMOUNT REIMBURSED TO COUNTY
Lease 24 months \$2,000/month	\$ 48,000.00			
Utilities - Electric, water, HVAC	\$ 9,600.00			
Internet	\$ 2,400.00			
Insurance Liability & contents	\$ 2,400.00			
Maintenance	\$ 1,500.00			
Supplies	\$ 1,200.00			
TOTAL Requested	\$ 65,100.00			

TOTAL Requested \$ 65,100.00

AGENDA

ITEM # 8:

CITIZEN COMMENTS

AGENDA

ITEM # 9A:

**STATE OF SOUTH CAROLINA
JASPER COUNTY**

RESOLUTION NUMBER R-2026-32

RESOLUTION OF JASPER COUNTY COUNCIL

**A RESOLUTION APPROVING THE STATE ACCOMMODATIONS TAX
ADVISORY COMMITTEE RECOMMENDATIONS AND AUTHORIZING THE
AWARD OF FUNDS FOR STATE ACCOMMODATIONS TAX REQUESTS
FOR THE FISCAL YEAR BEGINNING JULY 1, 2026**

WHEREAS, the County of Jasper estimates that the total State Accommodations Tax Funds to be received in Fiscal Year 2027 is \$237,800; and

WHEREAS, the estimated total State Accommodations Tax available for award to requesting organizations has been reduced by amounts required by State law to be distributed first to the County in the amounts of \$25,000 plus five percent (5%) of the remaining balance of the State Accommodations Tax received for the fiscal year; and

WHEREAS, thirty percent (30%) of the remaining balance of State Accommodations Tax must be allocated to a special fund and used only for advertising and promotion of tourism to develop and increase tourist attendance through the generation of publicity; and

WHEREAS, the Jasper County Chamber of Commerce has an existing, ongoing tourist promotion program; and

WHEREAS, the Jasper County Council may select an organization with an existing, ongoing tourist promotion program to manage the special fund to be used only for advertising and promotion of tourism; and

WHEREAS, the County has estimated a carry-forward of Accommodations Tax funds from Fiscal Year 2025 of \$157,847.83 which must be spent by the County within two years of receipt; and

WHEREAS, the total available State Accommodations Tax funds available for award to requesting organizations is \$296,183.83, adjusted for allocations mandated by the State and for the estimated carry-forward from the current fiscal year; and

WHEREAS, the Jasper County Accommodations Tax Advisory Committee, during its May 18, 2026, meeting, recommended the requests below to be funded; and

WHEREAS, the Jasper County Council finds the recommended requests and expenditures comply with applicable State laws regarding the use of State Accommodations Tax and accepts the recommendation of the Jasper County Accommodations Tax Advisory Committee

NOW, THEREFORE, BE IT RESOLVED THAT the Jasper County Council, in Council, assembled, hereby selects the Jasper County Chamber of Commerce to receive thirty percent (30%) of the balance remaining after the amounts allocated to the County have been deducted. Said funds shall be used only for advertising and promotion of tourism to develop and increase tourist attendance through the generation of publicity.

AND BE IT FURTHER RESOLVED THAT the Jasper County Council, in Council, assembled, hereby accepts the recommendation of the Accommodations Tax Advisory Committee, and authorizes the award of \$193,663 of the State Accommodations Tax requests to and for the following:

Organization	Purpose of Request	Amount of Request
Gopher Hill Festival	Marketing for Annual Festival	\$ 5,000
Jasper Soil & Water Conservation District / Blue Heron Nature Center	SC Welcome Center Tourism Week	\$ 2,000
Jasper County Chamber of Commerce	Digital Marketing Campaign	\$ 35,928
Jasper County Chamber of Commerce	Visitors Center Operations	\$ 15,000
JC 250 Committee	Revolutionary War Interpretation & Visitors Center	\$ 36,600
Morris Center for Lowcountry Heritage	2026-2027 Museum Advertising & Maintenance	\$ 18,395
Operation Patriots FOB	6 TH Annual Concert for the Heroes	\$ 35,000
Point South Merchants Association	Electric Bill for Street Lighting at Point South and 2 I95 Billboards	\$ 30,240
SC Lowcountry Tourism Commission	Support Tourism Promotion of Jasper County	\$ 15,500
TOTAL		<u>\$ 193,663.</u>

ADOPTED THIS THE 1ST DAY OF JUNE 2026, and effective AS OF THE FISCAL YEAR 2026 – 2027 BEGINNING ON JULY 1, 2026.

Joseph Arzillo, Vice Chairman

ATTEST:

**Wanda H. Giles
Clerk to Council**

Reviewed for form and draftsmanship by the Acting Jasper County Attorney.

Acting County Attorney

Date _____

AGENDA
ITEM # 9B:

**STATE OF SOUTH CAROLINA
JASPER COUNTY**

RESOLUTION NUMBER R-2026-33

**RESOLUTION OF JASPER COUNTY COUNCIL TO RATIFY
AND APPROVE THE ALLOCATION OF AN ADDITIONAL
\$26,700 TO THE JASPER COUNTY 250 COMMITTEE FROM
THE JASPER COUNTY LOCAL HOSPITALITY TAXES, AND
MATTERS RELATED THERETO**

WHEREAS, the County of Jasper estimated that the total Local Accommodations Tax Funds to be received in Fiscal Year 2026 is \$210,000; and

WHEREAS, the County of Jasper estimated that the total Local Hospitality Tax Funds to be received in Fiscal Year 2026 is \$560,000; and

WHEREAS, the County of Jasper estimated that the total cash surplus carry-forward from Fiscal Year 2025 is \$1,504,179 including interest; and

WHEREAS, on June 16, 2025, Jasper County Council awarded \$34,600 to the Jasper County 250 Committee from the Local Accommodations and Hospitality taxes in Resolution #R-2025-39; and

WHEREAS, the Jasper County 250 Committee would like to schedule a living history reenactment event in June 2026; and

WHEREAS, the scheduled State Accommodations Advisory Tax Committee meeting on May 18, 2026, will be held too late to book the event; and

WHEREAS, there is a surplus in the Local Hospitality Tax funds; and

WHEREAS, the Jasper County 250 Committee requests that the cost of the event be funded from the Local Hospitality Tax surplus, and

WHEREAS, the County Council approved the allocation of an additional \$26,700 to the Jasper County 250 Committee at its May 4, 2026, meeting; and

NOW THEREFORE, BE IT RESOLVED by Jasper County Council, in the council duly assembled and by the authority of the same that Jasper County Council hereby ratifies the May 4th, 2026, Council approval to allocate an additional \$26,700 to the Jasper County 250 Committee for a living history reenactment event to be held in June 2026;

BE IT FURTHER RESOLVED THAT, the County Council authorizes the Interim County Administrator, Mr. James Iwanicki, to execute any necessary contracts or agreements.

SIGNATURES FOLLOW

This Resolution No. R- 2026-33 was made on this 1st day of June 2026.

Joseph Arzillo, Vice Chairman

ATTEST:

**Wanda H. Giles
Clerk to Council**

Reviewed for form and draftsmanship by the Jasper County Attorney.

Acting County Attorney

Date

AGENDA

ITEM # 9C:

**STATE OF SOUTH CAROLINA
JASPER COUNTY**

RESOLUTION NUMBER R-2026-34

**RESOLUTION OF JASPER COUNTY COUNCIL TO RATIFY
AND APPROVE THE PROCUREMENT OF PLAYGROUND
EQUIPMENT AND PLAYGROUND SURFACE FOR GRAYS
COMMUNITY PARK, AND MATTERS RELATED THERETO**

WHEREAS, the Parks and Recreation Department purchased playground equipment and playground surface at Grays Community Park from Barrs Recreation, LLC; and

WHEREAS, Section 2.441, Article V Purchasing and Contracting Ordinance of Jasper County Code of Ordinances authorizes the chief purchasing officer to “either participate in, sponsor, conduct or administer a cooperative purchasing agreement for procurement of supplies, services or construction with one or more public procurement units in accordance with an agreement entered into between the participants”; and

WHEREAS, Section 2-443, Article V Purchasing and Contracting Ordinance of Jasper County Code of Ordinances authorizes the chief purchasing officer to “enter into an agreement, independent of the bid process and sale process of this article, with any public procurement unit for the cooperative use of supplies or services under the term agreed upon between the parties”; and

WHEREAS, the vendor Barrs Recreation LLC is a member of several cooperative purchasing organizations, including Equalis Group, Omnia Partners, and Sourcewell; and

WHEREAS, Jasper County is also a member of cooperative purchasing organizations including Equalis Group, Omnia Partners, and Sourcewell; and

WHEREAS, Section 2-404 (2) authorizes only the County Council to enter into contracts in excess of \$25,000 and all contracts for special services; and

WHEREAS, the total cost of the playground equipment and playground surface shall not exceed \$112,000; and

WHEREAS, there are sufficient funds in the current fiscal year 2026 Parks & Recreation budget line item 010-078-5040 PARK DEVELOPMENT; and

NOW THEREFORE, BE IT RESOLVED by Jasper County Council, in the council duly assembled and by the authority of the same that Jasper County Council hereby is of the belief and finds that the requirements of Article V, Sec. 2-443 are met and hereby ratifies the purchase of the playground equipment and playground surface for Grays Community Park.

SIGNATURES FOLLOW

This Resolution No. R- 2026-34 was made on this 1st day of June 2026.

Joseph Arzillo, Vice Chairman

ATTEST:

**Wanda H. Giles
Clerk to Council**

Reviewed for form and draftsmanship by the Jasper County Attorney.

Acting County Attorney

Date

For Information Only

Ship To

Jasper County Parks & Recreation
1458 Red Dam Road
HARDEEVILLE, SC 29927

Bill To

Jasper County Parks & Recreation
1458 Red Dam Road
HARDEEVILLE, SC 29927

Purchase Order
No. 2026-00001304

DATE 02/23/2026

VENDOR 3677 - BARRS RECREATION, LLC
Reprint Purchase Order

PURCHASE ORDER NUMBER MUST APPEAR ON ALL INVOICES, SHIPPERS, BILL OF LADING AND CORRESPONDENCE

Contact

BARRS RECREATION, LLC
36 DIANE STREET
STE A
PITTSBORO, NC 27312

DELIVER BY
SHIP VIA
FREIGHT TERMS
PAGE 1 of 1
ORIGINATOR: Wendy Marlow

REFERENCE #

QUANTITY	UNIT	DESCRIPTION	STATUS	UNIT COST	TOTAL COST
1.0000	Each	Playground and surface at Grays Community Park- Parks & Rec 010-078-5040 - PARK DEVELOPMENT 102,188.64 <i>Creighton</i> <i>\$4,500 added</i> <i>\$106,688.64</i>	Open	102,188.6400	\$102,188.64
TOTAL DUE					\$102,188.64

H. Kimberly Burgess

Special Instructions

ESTIMATE

Barrs Recreation, LLC
36 Diane St
Pittsboro, NC 27312-9963

info@barrsrec.com
+1 (919) 781-4870
www.barrsrec.com

PO # 1304
078-5040
Approved



Jasper County Park & Rec
Bill to
Wendy Marlow
1458 Red Dam Road
Hardeeville, SC 29927

Ship to
Wendy Marlow
jasper co

Estimate details

Estimate no.: 2459
Estimate date: 01/20/2026

Sales Rep: Johnny Davis

#	Product or service	Description	Qty	Rate	Amount
1.		*Barrs Recreation State of SC PA #4400033958 in conjunction with BCI Burke NASPO Agreement #PO-10700- 00015859 / SC PA 4400033957			
2.	BCI Burke	Drawing #405-197189-3	1	\$30,083.00	\$30,083.00
3.	Discount	SC State Contract Savings Amount	1	-\$2,105.81	-\$2,105.81
4.	Discount	Burke's Special Pricing Additional Saving Amount	1	-\$5,153.51	-\$5,153.51
5.	Freight	Freight - This price is good for 30 days from the date of this estimate, and must be re-calculated if your order is placed after that time frame.	1	\$3,450.00	\$3,450.00
6.	Installation	Installation of your commercial equipment Site and Installation Conditions - requirements to avoid additional fees: **Owner or Responsible Party Requirements:** - The owner or responsible party must be present on-site when the crew arrives to ensure clear communication regarding equipment orientation. **Site Preparation:** - The installation site must be ready and accessible on the scheduled day. The site	1	\$8,500.00	\$8,500.00

must be graded within a 1% slope. There should be adequate space available for equipment as previously determined.

****Soil Conditions:****

- The soil must be free from excessive rocks, roots, debris, and water issues.

****Line Marking:****

- Barrs Recreation will perform standard 811 markings. The owner must locate and clearly mark all private utility lines, if they are not marked and incur damage during installation – the owner will be responsible for repair costs.

****Security Measures:**** - If Security measures go beyond Caution Tape or Orange fencing, arrangements must be discussed and agreed upon before the crew arrives (this will be quoted separately). Please note that we do not provide surveillance against theft or intentional damage.

****Unless otherwise indicated, this does not include Bond or Permit Fees**

7. Service	Remove existing EWF and leave on site	2550	\$3.00	\$7,650.00
8. Surfacing	Provide / Install Pour In Place Rubber Safety Surfacing (2550 SF)	2550	\$24.00	\$61,200.00
9. Discount	SC Contract Savings Amount on Surfacing	1	-\$3,060.00	-\$3,060.00
10. Supplemental Warranty	In addition to BCI Burke's 100% Non-prorated warranty, Barrs Recreation offers Value Added Service of 100% FREE replacement costs on all warranted BCI Burke products if installed by Barrs Recreation throughout the duration of the warranty period. The warranted items are shipped directly to Barrs Rec and are installed FREE OF CHARGE by our qualified installer(s). This results in Zero out-of-pocket costs to our customers on all warranted Burke Products. Our commitment to higher quality products and service makes this possible.	1	\$0.00	\$0.00

Subtotal \$100,563.68

Sales tax \$1,624.96

Total \$102,188.64

Accepted date

Accepted by



Barrs Recreation, LLC
36 Diane Street | Pittsboro, NC 27312 | 919-781-4870

Proposal 405-197189-3 | 1/29/2026

15297 Grays Hwy | Early Branch, SC 29916

January 29, 2026

Corey Bivens
Jasper Co. Parks & Rec
1458 Red Dam Rd.
Hardeeville, SC 29927

Dear Corey Bivens:

Barrs Recreation, LLC is delighted to provide Jasper Co. Parks & Rec with this playground equipment proposal.

This design was developed with your specific needs in mind, and we look forward to discussing this project further with you to ensure your complete satisfaction. Barrs Recreation, LLC is confident that this proposal will satisfy Jasper Co. Parks & Rec's functional, environmental, and safety requirements – and most importantly – bring joy and excitement to the children and families directly benefiting from your new playground.

You have our personal commitment to support this project and your organization in every manner possible, and we look forward to developing a long-standing relationship with Jasper Co. Parks & Rec. We appreciate your consideration and value this opportunity to earn your business.

Sincerely,

Johnny Davis
Sales Representative

Barrs Recreation, LLC
36 Diane Street
Pittsboro, NC 27312
www.barrsrec.com
www.bciburke.com

Phone: 919-781-4870
Fax: 919-781-5779
Email: johnny@barrsrec.com

COOPERATIVE PURCHASING OPTIONS

PLAYGROUNDS WITHOUT ALL THE PAPERWORK

Purchasing with contracts may sound intimidating, but getting your community playspace doesn't need to be a painful process of writing specifications, issuing RFP's and jumping through hoops – it can be simplified – we promise! As you continue planning for your new playground, review the Purchasing Contracts offered through our partners.

EQUALIS GROUP

Equalis is an innovative cooperative purchasing organization that believes in the power of partnership and that when you work together you achieve more. The basic premise of the Equalis cooperative purchasing organization is to leverage the combined buying power of all members for better pricing and favorable contract terms. Equalis Group uses the lead agency model for competitively bid contracts, provides our participants the savings they expect and offers efficiencies and peace of mind within the procurement process. It is our mission to continuously improve the measurable and meaningful impact of cooperative services for everyone throughout the supply chain.

GOVMVMT

GOVMVMT is a non-profit group purchasing organization that meets the highest industry standards while putting the public's interest at the forefront of everything they do. Each one of GOVMVMT's first-class suppliers has consciously joined their mission to create the most credible, ethical, and public agency-focused non-profit cooperative purchasing program in the country.

GSA

Federal parks, child development programs, military bases and other agencies are a major priority for BCI Burke, and agencies can purchase Burke playgrounds through Burke's GSA contract for installation virtually anywhere in the world.

OMNIA PARTNERS

OMNIA Partners, Public Sector (Subsidiary National IPA) is the largest and most experienced organization in purchasing and supply chain management. Comprised of participants and suppliers in the public sector, we bring together industry-leading buying power and world-class suppliers to offer an extensive portfolio of competitively solicited and publicly awarded contracts and partnerships. OMNIA Partners is proud to offer more value and resources to state and local government, higher education, K-12 education and non-profits.

SOURCEWELL

As a leader in cooperative purchasing, Sourcewell is passionate about helping members fulfill their public service missions. Sourcewell builds strong relationships with members and vendors to develop practical solutions together.

The easiest way to Join Our Movement is to call your local Representative at 800.266.1250 or visit bciburke.com/rep. Our passion is bringing play to communities like yours and we can't wait to help you get started!



BCIBURKE.COM

Burke

800.266.1250

FEATURED PLAY EVENTS



ROCK 'N' ROLL SLIDE

This exclusive slide adds excitement to your playgrounds. It features 'Burke Built™' quality, and the double-wall compounded plastic construction means it is stronger and will last longer.



2 Seat Rocker

Let's Rock! Burke's line of Rockers feature heavy-duty torsion springs and available in 2 Seat, 4 Seat and Standing versions. Rock your playground with these awesome freestanding basics events!

DESIGN SUMMARY

Barrs Recreation, LLC is very pleased to present this Proposal for consideration for the Grays Community Park located in Early Branch. BCI Burke Company, LLC has been providing recreational playground equipment for over 100 years and has developed the right mix of world-class capabilities to meet the initial and continuing needs of Jasper Co. Parks & Rec. We believe our proposal will meet or exceed your project's requirements and will deliver the greatest value to you.

The following is a summary of some of the key elements of our Proposal:

- Project Name: Grays Community Park
- Project Number: 405-197189-3
- User Capacity: 34
- Age Groups: 5 to 12, 2 to 12
- Dimensions: 50' 5" x 48' 10"
- Designer: Payton Jens

Barrs Recreation, LLC has developed a custom playground configuration based on the requirements as they have been presented for the Grays Community Park playground project. Our custom design will provide a safe and affordable playground environment that is aesthetically pleasing, full of fun for all users and uniquely satisfies your specific requirements. In addition, proposal # 405-197189-3 has been designed with a focus on safety, and is fully compliant with ASTM F1487 and CPSC playground safety standards.

We invite you to review this proposal for the Grays Community Park project and to contact us with any questions that you may have.

Thank you in advance for giving us the opportunity to make this project a success.

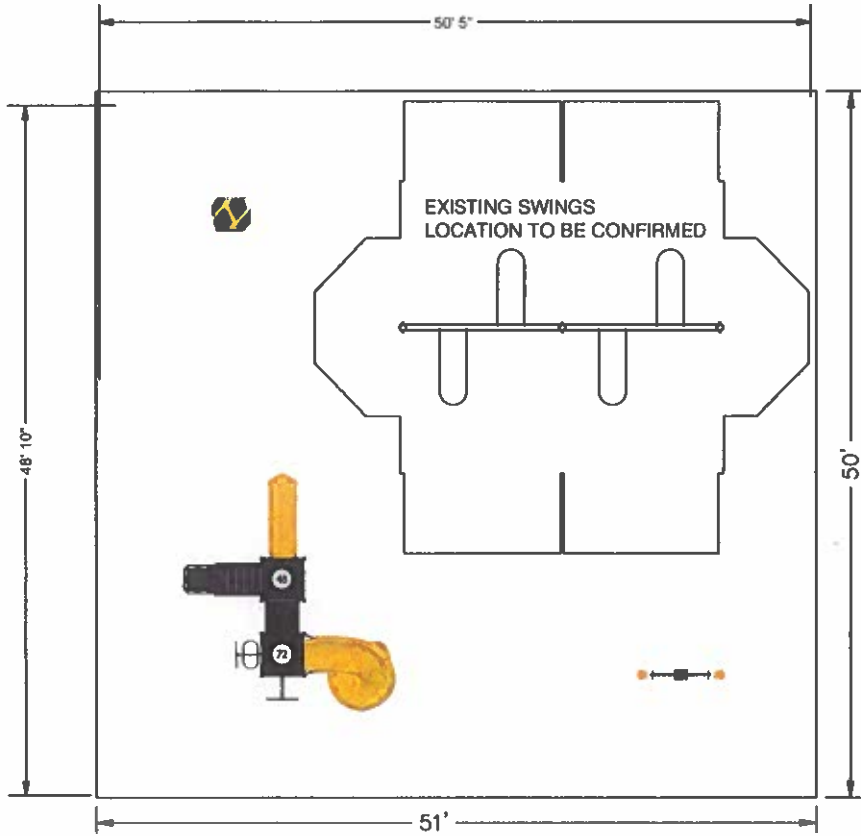

NOTE: ALTHOUGH ALL ATTEMPTS HAVE BEEN MADE TO PROVIDE AN ACCURATE SITE IT MAY NOT TRULY REPRESENT THE AREA WHERE THIS STRUCTURE IS TO BE PLACED.

SERIES: Burke Basics | Synergy

GROUP: Structure/Freestanding

DESIGNED FOR AGES: 5 to 12, 2 to 12

Grays Community Park
Early Branch, SC 29916

Burke
PLAY THAT MOVES YOU

SITE PLAN VIEW

01/29/2026

Barrs Recreation, LLC

405-197189-3
Designer: Payton Jens

UCI BURKE COMPANY, LLC | PO BOX 549 FORD DU LAC, WI 53030-0549 | 920.921.19220 | BCI@BURKE.COM

OVERALL BOUNDING OF USE ZONES
Area: 2456.4 sq. ft.
Perimeter: 198.3 ft.
STRUCTURE SIZE: 10"x50' 5"
POST SIZE(S): 5"

**The space requirements shown here are to ASTM standards. Requirements for other standards may be different.

PLAYGROUND ACCESSIBILITY (Provided/Required)					
TOTAL EVENTS	ELEVATED EVENTS	TRANSFER ACCESSIBLE EVENTS	RAMP ACCESSIBLE EVENTS	GROUND EVENTS	TYPES OF GROUND EVENTS
7	5 / 3	5 / 0	0 / 0	2 / 2	2 / 2

The use and layout of play components identified in this plan conform to the CPSC guidelines. U.S. CPSC recommends the separation of age groups in playground layouts.

Warning: Accessible safety surfacing material is required beneath and around this equipment that is compliant with ASTM, CPSC, and ADAAG requirements.

SERIES Synergy

GROUP: Structure

DESIGNED FOR AGES: 5 to 12

Grays Community Park
Early Branch, SC 29916



01/29/2026
Barrs Recreation, LLC
405-197189-3
Designer: Payton Jens

SITE PLAN VIEW

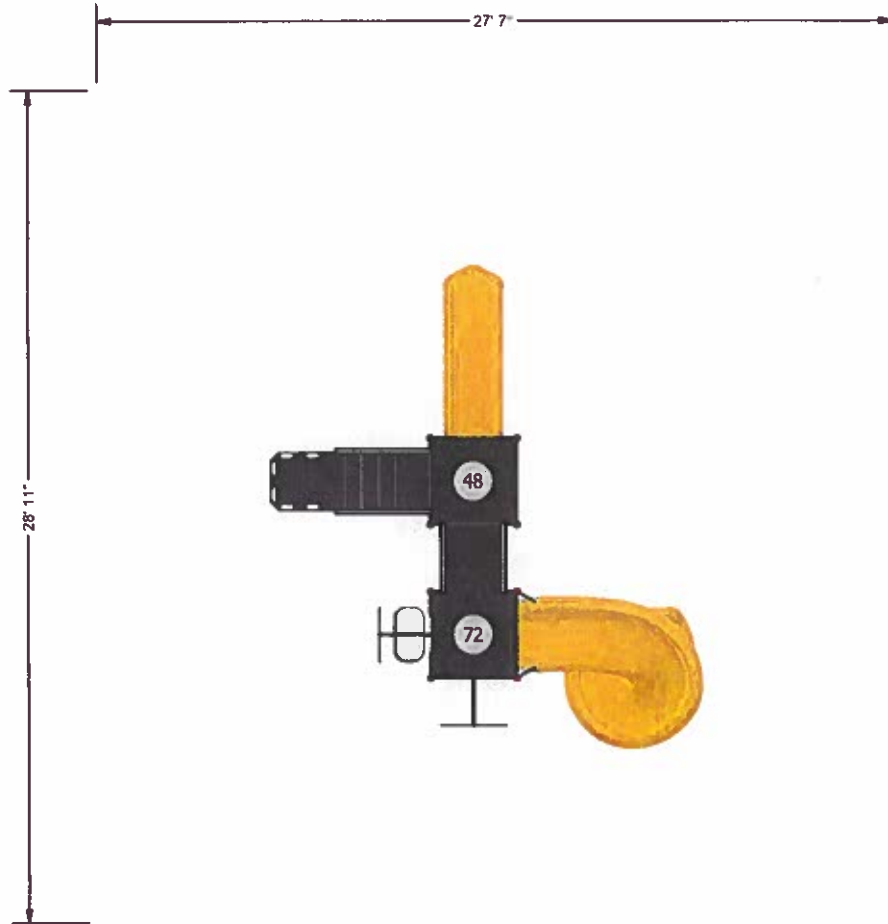

OVERALL BOUNDING OF USE ZONES

Area: 2456.4 sq ft
Perimeter: 198.3 ft

STRUCTURE SIZE: 10'x50' 5"
POST SIZE(S): 5"

**The space requirements shown here are to ASTM standards. Requirements for other standards may be different.

PLAYGROUND ACCESSIBILITY (Provided/Required)

TOTAL EVENTS	ELEVATED EVENTS	TRANSFER ACCESSIBLE EVENTS	RAMP ACCESSIBLE EVENTS	GROUND EVENTS	TYPES OF GROUND EVENTS
7	5/3	5/0	0/0	2/2	2/2

The use and layout of play components identified in this plan conform to the CPSC guidelines. U.S. CPSC recommends the separation of age groups in playground layouts.

Warning: Accessible safety surfacing material is required beneath and around this equipment that is compliant with ASTM, CPSC, and ADAAG requirements.

SERIES Burke Basics

GROUP: Freestanding

DESIGNED FOR AGES: 2 to 12

Grays Community Park
Early Branch, SC 29916

01/29/2026

Burke
PLAY THAT MOVES YOU

Barrs Recreation, LLC
405-197189-3
Designer: Payton Jens

SITE PLAN VIEW

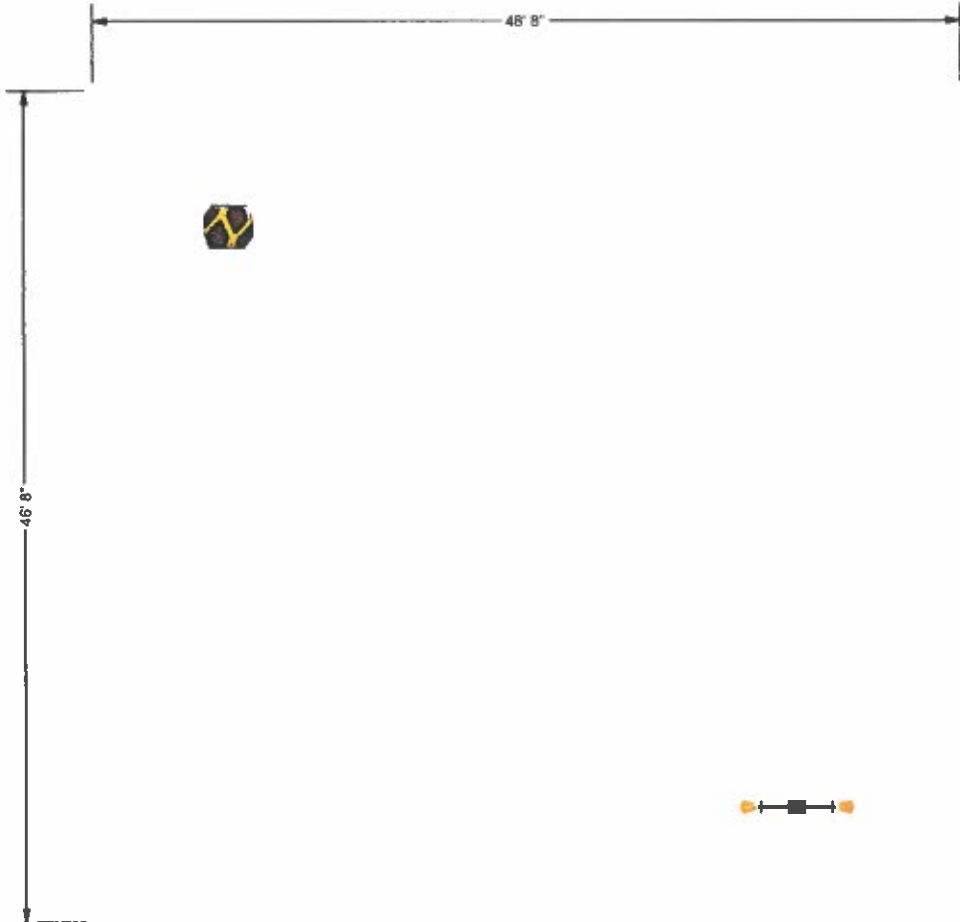

OVERALL BOUNDING OF USE ZONES
Area: 2456.4 sq. ft.
Perimeter: 198.3 ft.
STRUCTURE SIZE: 10'x50' 5"
POST SIZE(S): 5"

**The space requirements shown here are to ASTM standards. Requirements for other standards may be different.

PLAYGROUND ACCESSIBILITY (Provided/Required)

TOTAL EVENTS	ELEVATED EVENTS	TRANSFER ACCESSIBLE EVENTS	RAMP ACCESSIBLE EVENTS	GROUND EVENTS	TYPES OF GROUND EVENTS
7	5/3	5/0	0/0	2/2	2/2

The use and layout of play components identified in this plan conform to the CPSC guidelines. U.S. CPSC recommends the separation of age groups in playground layouts.

Warning: Accessible safety surfacing material is required beneath and around this equipment that is compliant with ASTM, CPSC, and ADAAG requirements.

ITEM	COMP.	DESCRIPTION
1	290-0102	SQUARE PLATFORM
2	690-1000	METAL STRUCTURE ID LABEL
3	690-0512	METAL 5-12 WARNING LABEL
4	490-0132	ROCK N ROLL SLIDE 40"-46"
5	490-0141	SLIDE SIT DOWN BAR
6	390-0149	TRANSFER STATION, HANDRAIL 46"
7	390-0101	24" TRANSITION STAIR W/BARRIERS
8	390-0190	CENTPEDE CLIMBER 64"-72"
9	290-0110	CLIMBER ENCLOSURE
10	390-0309	SHAKE CLIMBER 56"-72"
11	490-0231	EXTREME TWIST SPIRAL SLIDE
12	390-0156	TREE BRANCH CLIMBER 46"

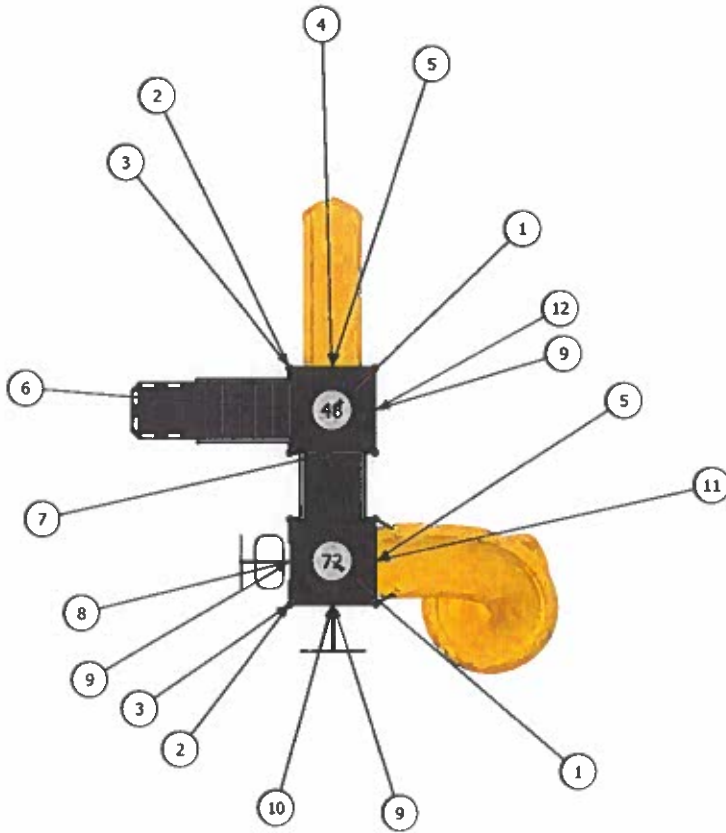

SERIES Synergy

GROUP: Structure

DESIGNED FOR AGES: 5 to 12

Grays Community Park

Early Branch, SC 29916

Burke
PLAY THAT MOVES YOU

COMPONENT VIEW

01/29/2026

Barrs Recreation, LLC

405-197189-3

Designer: Payton Jens

BURKE COMPANY, LLC | PO BOX 649 FOND DU LAC, WI 53036-0649 | 920.921.0270 | ICBURKE.COM

ITEM	COMP.	DESCRIPTION
1	560-0073	MIDD SPUNNER
2	570-0055	2 SEAT ROCKER

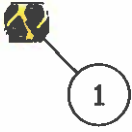

SERIES Burke Basics

COMPONENT VIEW

GROUP:
Freestanding

Grays Community Park
Early Branch, SC 29916

01/29/2026

DESIGNED FOR AGES:
2 to 12

Burke
PART THAT MOVES YOU

Barrs Recreation, LLC
405-197189-3
Designer: Payton Jens

BICI BURKE COMPANY, LLC | PO BOX 549 FOND DU LAC, WI 549060549 | 920.071.0220 | BICIBURKE.COM

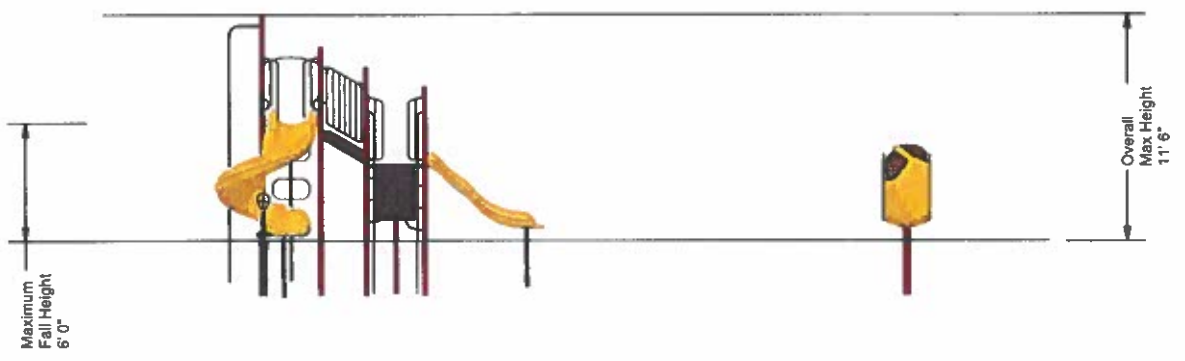

SERIES Burke Basics | Synergy

ELEVATION VIEW

GROUP:
Structure/Freestanding

DESIGNED FOR AGES:
5 to 12, 2 to 12

Grays Community Park
Early Branch, SC 29916



01/29/2026
Barrs Recreation, LLC
405-197189-3
Designer: Payton Jens



SERIES Synergy

GROUP: Structure

DESIGNED FOR AGES:
5 to 12

Grays Community Park
Early Branch, SC 29916



01/29/2026
Barrs Recreation, LLC
405-197189-3
Designer: Payton Jens

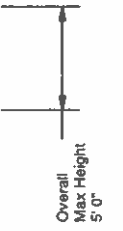

SERIES Burke Basics

GROUP: Freestanding

DESIGNED FOR AGES:
2 to 12

Grays Community Park
Early Branch, SC 29916



01/29/2026
Barrs Recreation, LLC
405-197189-3
Designer: Payton Jens



SERIES Burke Basics | Synergy

ISOMETRIC VIEW

GROUP:
Structure/Freestanding

Grays Community Park
Early Branch, SC 29916

01/29/2026

DESIGNED FOR AGES:
5 to 12, 2 to 12

Burke
PLAY THAT MOVES YOU

Barrs Recreation, LLC
405-197189-3
Designer: Payton Jens



SERIES Synergy

GROUP:
Structure

DESIGNED FOR AGES:
5 to 12

Grays Community Park
Early Branch, SC 29916

Burke
PLAY THAT MOVES YOU

01/29/2026

Barrs Recreation, LLC
405-197189-3
Designer: Payton Jens



SERIES Burke Basics

ISOMETRIC VIEW

GROUP:
Freestanding

Grays Community Park
Early Branch SC 29916

01/29/2026

DESIGNED FOR AGES:
2 to 12



Barrs Recreation, LLC
405-197189-3
Designer: Payton Jens

PROPOSAL 405-197189-3 | 1/29/2026 | 2026 PRICING

The play components identified in this proposal are IPEMA certified. The use and layout of these components conform to the requirements of ASTM F1487 and CPSC. To verify product certification, visit www.ipema.org.



The space requirements shown in this proposal are to ASTM standards. Requirements for other standards may be different.

Structure

Synergy

Component No.	Description	Qty	User Cap.	Ext. User Cap.	Weight	Ext. Weight
072-0300-127C	3 1/2" OD X 127" CAPPED POST	2	0	0	47	94
072-0300-139C	3 1/2" OD X 139" CAPPED POST	2	0	0	51	102
072-0300-147C	3 1/2" OD X 147" CAPPED POST	1	0	0	54	54
072-0300-151C	3 1/2" OD X 151" CAPPED POST	1	0	0	55	55
072-0300-171C	3 1/2" OD X 171" CAPPED POST	2	0	0	63	126
290-0102	SQUARE PLATFORM	2	4	8	59	118
290-0110	CLIMBER ENCLOSURE	3	0	0	21	63
390-0101	24" TRANSITION STAIR W/BARRIERS	1	5	5	143	143
390-0149	TRANSFER STATION, HANDRAIL 48"	1	6	6	217	217
390-0156	TREE BRANCH CLIMBER 48"	1	2	2	15	15
390-0198	CENTIPEDE CLIMBER 64"-72"	1	3	3	39	39
390-0309	SNAKE CLIMBER 56"-72"	1	3	3	48	48
490-0132	ROCK N ROLL SLIDE 40"-48"	1	1	1	76	76
490-0141	SLIDE SIT DOWN BAR	2	0	0	5	10
490-0231	EXTREME TWIST SPIRAL SLIDE	1	2	2	192	192
690-0512	METAL 5-12 WARNING LABEL	2	0	0	1	2
690-1000	METAL STRUCTURE ID LABEL	2	0	0	1	2

Total User Capacity: 30
Total Weight: 1,356 lbs
Total Price: \$23,007

Freestanding

Burke Basics

Component No.	Description	Qty	User Cap.	Ext. User Cap.	Weight	Ext. Weight
560-0073	NIDO SPINNER	1	2	2	185	185
570-0055	2 SEAT ROCKER	1	2	2	131	131

Total User Capacity: 4
Total Weight: 316 lbs
Total Price: \$7,076

Special Notes:

Prices do not include freight, unloading, material storage, site excavation/preparation, removal of existing equipment, removal of excess soil from footing holes, site security, safety surfacing, installation, or sales tax (if applicable). Prices are based on standard colors per CURRENT YEAR BCI Burke Catalog. Custom colors, where available, would be an extra charge. **Pricing is valid for 30 days from the date of this proposal.**

COLOR SELECTION LIST | Default Color Option

GROUP 1 (Structure)

Accessory: Brown
HDPE 1 Color: Olive
HDPE 2 Color: Olive-Black-Olive
Platform: Gray
Post: Redwood
Rotomold Plastic: Yellow

GROUP 2 (Freestanding)

Accessory: Brown
HDPE 1 Color: Olive
HDPE 2 Color: Olive-Black-Olive
Platform: Gray
Post: Redwood
Rotomold Plastic: Yellow

COLOR SELECTION LIST | PopColors

GROUP 1 (Structure)

Accessory: Brown
HDPE 1 Color: Olive
HDPE 2 Color: Olive-Black-Olive
Platform: Gray
Post: Redwood
Rotomold Plastic: Yellow

GROUP 2 (Freestanding)

Accessory: Brown
HDPE 1 Color: Olive
HDPE 2 Color: Olive-Black-Olive
Platform: Gray
Post: Redwood
Rotomold Plastic: Yellow

COLORS THAT MOVE YOU

POWDER COAT PAINT



PLATFORMS

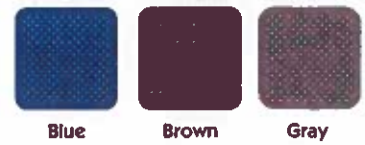

SOLIS HUE TOPPERS



TRADITIONAL SERIES SITE AMENITIES



ROCKIT CLIMBERS

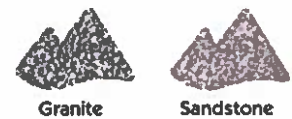

HDPE PLASTIC PANELS

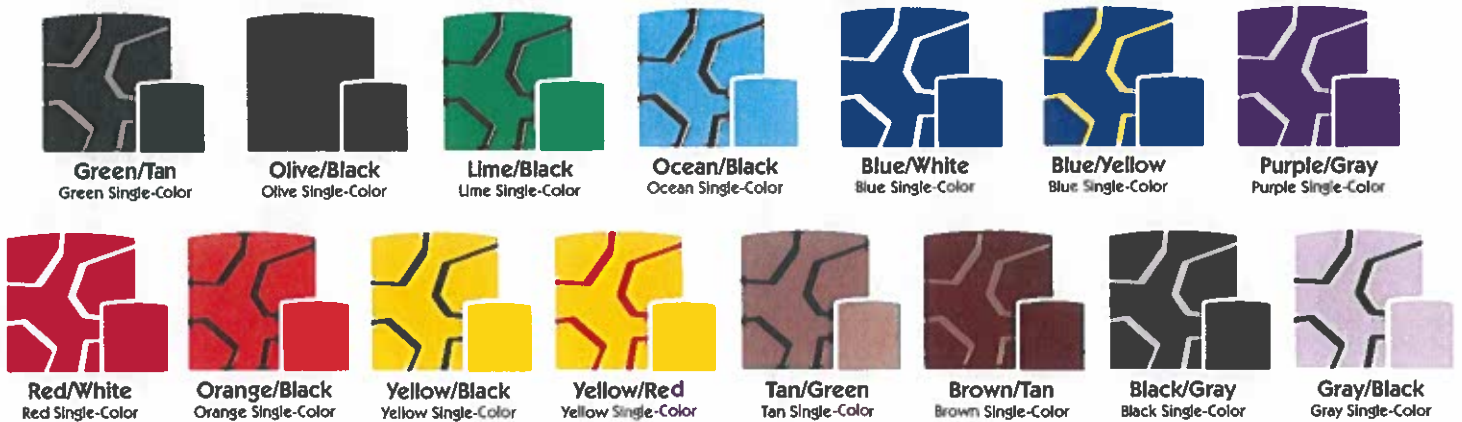

SHADE CANOPIES



ROTOMOLD PLASTIC



VISIT BCIBURKE.COM/COLOR TO CUSTOMIZE YOUR PLAYGROUND COLORS!

BURKE GENERATIONS WARRANTY®

BCI Burke Company, LLC ("Burke") warrants that all standard products are warranted to be free from defects in materials and workmanship, under normal use and service, for a period of one (1) year from the date of shipment.

We stand behind our products.

In addition, the following products are warranted, under normal use and service from the date of shipment as follows:

- One Hundred (100) Year Limited Warranty on aluminum and steel upright posts (including Nucleus®, Nucleus Evolution®, Nucleus Aspire®, Intensity®, Level X®, Synergy®, Synergy Imagination® & 4ME®) against structural failure due to corrosion, deterioration or workmanship.
- One Hundred (100) Year Limited Warranty on KoreConnect™ Clamp Castings against structural failure due to corrosion, deterioration or workmanship.
- One Hundred (100) Year Limited Warranty on Hardware (nuts, bolts, washers).
- One Hundred (100) Year Limited Warranty on bolt-through and direct-bolt fastening and clamp systems (Synergy®, Intensity®, Nucleus®).
- Twenty-Five (25) Year Limited Warranty on spring assemblies and aluminum cast animals.
- Fifteen (15) Year Limited Warranty on structure platforms and decks, metal roofs, table tops, bench tops, railings and barriers against structural failure due to materials or workmanship.
- Fifteen (15) Year Limited Warranty on all plastic components against structural failure due to materials or workmanship.
- Ten (10) Year Limited Warranty on ShadePlay® Canopies fabric, threads, and cables against degradation, cracking or material breakdown resulting from ultra-violet exposure, natural deterioration or manufacturing defects. This warranty is limited to the design loads as stated in the specifications.
- Ten (10) Year Limited Warranty on NaturePlay® Boulders and GFRC products against structural failure due to natural deterioration or workmanship. Natural wear, which may occur with any concrete product with age, is excluded from this warranty.
- Ten (10) Year Limited Warranty on Full Color Custom Signage against manufacturing defects that cause delamination or degradation of the sign. Full Color Custom Signs also carry a two (2) year warranty against premature fading of the print and graphics on the signs.
- Five (5) Year Limited Warranty on Nucleus®, Intensity®, and RopeVenture® cables against premature wear due to natural deterioration or manufacturing defects. Determination of premature wear will be at the manufacturer's discretion.
- Five (5) Year Limited Warranty on rubber belt material against premature wear due to natural deterioration or manufacturing defects. Determination of premature wear will be at the manufacturer's discretion.
- Five (5) Year Limited Warranty on moving parts, including swing components, against structural failure due to materials or workmanship.
- Five (5) Year Limited Warranty on PlayEnsemble® cables and mallets against defects in materials and workmanship.
- Three (3) Year Limited Warranty on electronic panel speakers, sound chips and circuit boards against electronic failure caused by manufacturing defects.

The warranty stated above is valid only if the equipment is erected in conformity with the layout plan and/or installation instructions furnished by BCI Burke Company, LLC using approved parts; have been maintained and inspected in accordance with BCI Burke Company, LLC instructions. Burke's liability and your exclusive remedy hereunder will be limited to repair or replacement of those parts found in Burke's reasonable judgment to be defective. Any claim made within the above stated warranty periods must be made promptly after discovery of the defect. A part is covered only for the original warranty period of the applicable part. Replacement parts carry the applicable warranty from the date of shipment of the replacement from Burke. After the expiration of the warranty period, you must pay for all parts, transportation and service charges.

Burke reserves the right to accept or reject any claim in whole or in part. Burke will not accept the return of any product without its prior written approval. Burke will assume transportation charges for shipment of the returned product if it is returned in strict compliance with Burke's written instructions.

THE FOREGOING WARRANTIES ARE EXCLUSIVE AND IN LIEU OF ANY OTHER WARRANTY, EXPRESS OR IMPLIED, INCLUDING BUT NOT LIMITED TO ANY IMPLIED WARRANTY OR MERCHANTABILITY OR FITNESS FOR A PARTICULAR PURPOSE. IF THE FOREGOING DISCLAIMER OF ADDITIONAL WARRANTIES IS NOT GIVEN FULL FORCE AND EFFECT, ANY RESULTING ADDITIONAL WARRANTY SHALL BE LIMITED IN DURATION TO THE EXPRESS WARRANTIES AND BE OTHERWISE SUBJECT TO AND LIMITED BY THE TERMS OF BURKE'S PRODUCT WARRANTY. SOME STATES DO NOT ALLOW THE EXCLUSION OF CERTAIN IMPLIED WARRANTIES, SO THE ABOVE LIMITATION MAY NOT APPLY TO YOU.

Warranty Exclusions: The above stated warranties do not cover: "cosmetic" defects, such as scratches, dents, marring, or fading; damage due to incorrect installation, vandalism, misuse, accident, wear and tear from normal use, exposure to extreme weather, immersion in salt or chlorine water, unauthorized repair or modification, abnormal use, lack of maintenance, or other cause not within Burke's control; and

Limitation of Remedies: Burke is not liable for consequential or incidental damages, including but not limited to labor costs or lost profits resulting from the use of or inability to use the products or from the products being incorporated in or becoming a component of any other product. If, after a reasonable number of repeated efforts, Burke is unable to repair or replace a defective or nonconforming product, Burke shall have the option to accept return of the product, or part thereof, if such does not substantially impair its value, and return the purchase price as the buyer's entire and exclusive remedy. Without limiting the generality of the foregoing, Burke will not be responsible for labor costs involved in the removal of products or the installation of replacement products. Some states do not allow the exclusion of incidental damages, so the above exclusion may not apply to you.

The environment near a saltwater coast can be extremely corrosive. Some corrosion and/or deterioration is considered "normal wear" in this environment. Product installed within 500 yards of a saltwater shoreline will only be covered for half the period of the standard product warranty, up to a maximum of five years, for defects caused by corrosion. Products installed in direct contact with saltwater or that are subjected to salt spray are not covered by the standard warranty for any defects caused by corrosion.

Contact your local Burke Representative for warranty information regarding Burke Turf® and Burke Tile products.

Terms of Sale

Pricing: Prices published in this catalog are in USD, are approximate and do not include shipping & handling, surfacing, installation nor applicable taxes. All prices are subject to change without notice. Contact your Burke representative for current pricing. Payments are to be made in USD.

Weights: Weights are approximate and may vary with actual orders.

Installation: All equipment is shipped unassembled. For a list of factory-certified installers in your area, please contact your Burke representative.

Specifications: Product specifications in this catalog were correct at the time of publication. However, product improvements are ongoing at Burke, and we reserve the right to change or discontinue specifications without notice.

Loss or Damage In Transit: A signed bill of lading is our receipt from a carrier that our shipment to you was complete and in good condition upon arrival. Before you sign, please check the Bill of Lading carefully when the shipment arrives to make sure nothing is missing and there are no damages. Once the shipment leaves our plant, we are no longer responsible for any damage, loss or shortage.

For more information regarding the warranty, call Customer Service at 920-921-9920 or 800-356-2070.

01/2025

GRAYS COMMUNITY PARK 3



#: 405-197189-3-R1

GRAYS COMMUNITY PARK 3

BU
PLAY TH
SCHEIDT &

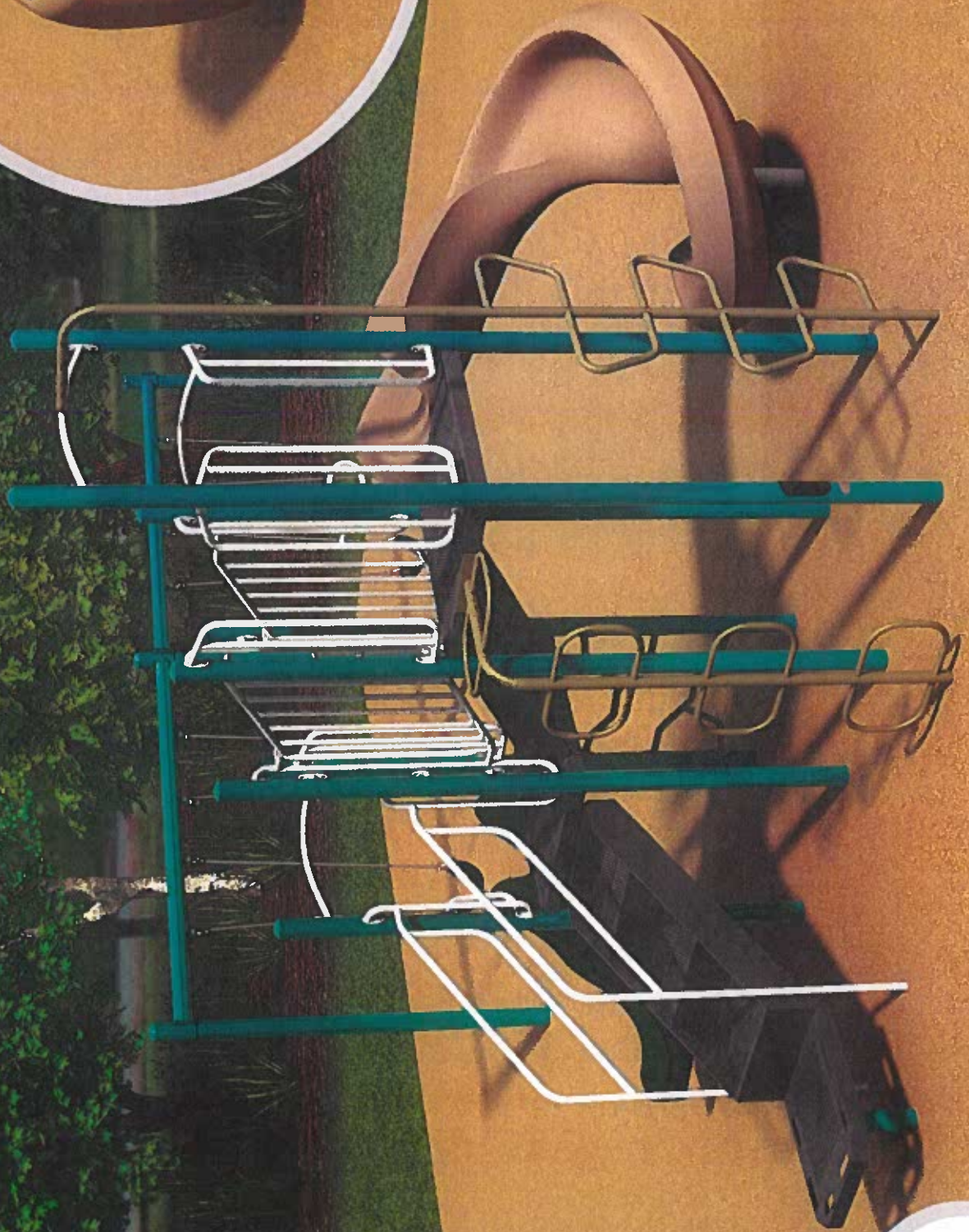

302

GRAYS COMMUNITY PARK 3

ke
XPS YOU
00.266.1250



AGENDA

ITEM # 9D:

The material for this item was not available. This item will need to be removed from the agenda

AGENDA
ITEM # 9E

**STATE OF SOUTH CAROLINA
JASPER COUNTY**

RESOLUTION NUMBER R-2026-36

RESOLUTION OF JASPER COUNTY COUNCIL

**A RESOLUTION AUTHORIZING THE AWARD OF FUNDS FOR REQUESTS FOR
LOCAL ACCOMMODATIONS AND HOSPITALITY TAXES FOR FISCAL YEAR
BEGINNING JULY 1, 2026.**

WHEREAS, the County of Jasper estimates that the total Local Accommodations Tax Funds to be received in Fiscal Year 2027 is \$230,000; and

WHEREAS, the County of Jasper estimates that the total Local Hospitality Tax Funds to be received in Fiscal Year 2027 is \$700,000; and

WHEREAS, the County of Jasper estimates an available carry-forward of funds of approximately \$1,673,000; and

WHEREAS, the County wishes to award local organizations and event sponsors Local Accommodations and Local Hospitality Tax funds to promote tourism within the unincorporated portions of Jasper County; and

WHEREAS, the Jasper County Council requires each recipient of Jasper County local accommodation tax funds and local hospitality tax funds to acknowledge the source of the funding on promotional material(s) for the event or organization; and

WHEREAS, the Jasper County Council finds the recommended requests and expenditures comply with applicable State laws and County ordinances regarding the use of Local Accommodations Tax and Local Hospitality; and

NOW, THEREFORE, BE IT RESOLVED THAT Jasper County Council, in Council,

assembled, hereby awards the Local Accommodations Tax and Local Hospitality fund requests in the amount of \$994,002 to and for the following:

Organization	Purpose of Request	Recommended Amount
Blue Heron Nature Ctr./Jasper Conservation District	Blue Heron Nature Center Billboard	\$ 8,000
Gopher Hill Festival	Gopher Hill Festival	\$ 15,000
Jasper County Chamber of Commerce	Jasper County Billboard (Point South)	\$ 10,560
Jasper County Chamber of Commerce	Swingin' Medallions Concert	\$ 16,000
Jasper County Historical Society/Chamber	Historical Society's Museum (within Visitor's Center)	\$11,332
JC 250 Committee	JC Revolutionary War Interpretation & Visitor Center	\$ 65,100
Keep Jasper County Beautiful	KJB Litter Prevention Program - Crew / Marketing / Supplies	\$ 30,000
Morris Center for Lowcountry Heritage	2026-2027 Advertising and Maintenance	\$ 18,000
Operation Patriots FOB	6th Annual Concert for the Heroes	\$115,000
Point South Merchants Assoc.	I-95 & US 17 PointSouth Billboards	\$ 66,000
Point South Merchants Assoc.	Jasper County Sheriff Patrol Officer	\$ 37,000
Project Freedom 326	2026 Pocotaligo Point South Festival	\$ 13,500
SC Lowcountry Tourism Commission	Promotion of Jasper County & the Lowcountry	\$ 15,000
Jasper County	Improvements to Exit 33	<u>\$ 206,000</u>
Jasper County	Exit 33 Lighting—Utility Cost	<u>\$ 17,510</u>
Sgt. Jasper Park, Jasper County	Marketing, Pond Maintenance, and Park Development	<u>\$ 355,600</u>
TOTAL		\$ 994,002

AND BE IT FURTHER RESOLVED THAT the Jasper County Council, in Council assembled requires all recipients of state accommodations tax funds, local accommodations tax funds and local hospitality tax funds to acknowledge the source of the funds (Jasper County) on promotional material for the event or organization.

ADOPTED THIS THE 1ST DAY OF JUNE 2026, and effective AS OF THE FISCAL YEAR 2026 – 2027 BEGINNING ON JULY 1, 2026.

Joseph Arzillo, Vice Chairman

ATTEST:

**Wanda H. Giles
Clerk to Council**

Reviewed for form and draftsmanship by the Acting Jasper County Attorney.

Acting County Attorney

Date

FOR INFORMATON ONLY

**JASPER COUNTY
LOCAL ACCOMMODATIONS & HOSPITALITY TAX
FY26-27**

REVENUE	Budget Amount	
ESTIMATED LOCAL ACCOMMODATIONS TAX RECEIPTS FY26-27	25%	\$230,000.00
ESTIMATED LOCAL HOSPITALITY TAX RECEIPTS FY26-27	75%	\$700,000.00
EXCESS FUNDS AVAILABLE FOR CARRY-FORWARD		\$1,673,630.00
TOTAL		<u>\$2,603,630.00</u>

	<u>LAST YEAR</u>	<u>REQUEST</u>	<u>STAFF RECOMMENDED</u>	<u>COUNCIL APPROVED</u>
BLUE HERON NATURE CENTER / JASPER CONSERVATION DISTRICT	\$ 11,900.00	\$ 8,000.00	\$ 8,000.00	
GOPHER HILL FESTIVAL	\$ 15,000.00	\$ 15,000.00	\$ 15,000.00	
JASPER COUNTY CHAMBER OF COMMERCE (BILLBOARD POINT SOUTH)	\$ 10,560.00	\$ 10,560.00	\$ 10,560.00	
JASPER COUNTY CHAMBER OF COMMERCE (SWINGIN' MEDALLIONS CONCERT)	\$ -	\$ 16,000.00	\$ 16,000.00	
JASPER COUNTY CHAMBER VISITORS CTR. & JASPER COUNTY HISTORICAL SOCIETY	\$ 11,318.00	\$ 11,332.00	\$ 11,332.00	
JC 250 COMMITTEE (JC REVOLUTIONARY WAR INTERPRETATION & VISITORS CENTER)	\$ -	\$ 65,100.00	\$ 65,100.00	
KEEP JASPER COUNTY BEAUTIFUL (LITTER PREVENTION PROGRAM)	\$ 20,500.00	\$ 30,000.00	\$ 30,000.00	
LOWCOUNTRY & RESORT ISLANDS TOURISM COMMISSION	\$ 15,000.00	\$ 15,000.00	\$ 15,000.00	
MORRIS CENTER FOR LOWCOUNTRY HERITAGE	\$ 18,000.00	\$ 18,000.00	\$ 18,000.00	
OPERATION PATRIOTS FOB "CONCERT FOR HEROES"	\$ 89,600.00	\$ 115,000.00	\$ 115,000.00	
POINT SOUTH MERCHANTS ASSOCIATION (BILLBOARDS & SHERIFF PATROL OFFICER & PARTIAL STREET LIGHTING SERVICE)	\$ 99,500.00	\$ 103,000.00	\$ 103,000.00	
PROJECT FREEDOM 326 (POINT SOUTH FESTIVAL)	\$ 24,500.00	\$ 13,500.00	\$ 13,500.00	
RIDGELAND-CLAUDE DEAN AIRPORT	\$ 350,000.00	\$ 350,000.00	\$ 350,000.00	
JASPER COUNTY (IMPROVEMENTS TO EXIT 33)	\$ 200,000.00	\$ 206,000.00	\$ 206,000.00	
JASPER COUNTY (EXIT 33 LIGHTS-UTILITIES)	\$ 17,000.00	\$ 17,510.00	\$ 17,510.00	
JASPER COUNTY (SGT. JASPER PARK-MARKETING/MAINTENANCE/DEVELOPMENT)	\$ -	\$ 355,600.00	\$ 355,600.00	
TOTAL	<u>\$ 882,878.00</u>	<u>\$ 994,002.00</u>	<u>\$ 994,002.00</u>	

AGENDA
ITEM # 9F

**JASPER COUNTY, SOUTH CAROLINA
RESOLUTION NUMBER R-2026-26**

**A RESOLUTION OF JASPER COUNTY, SOUTH CAROLINA,
APPROVING THE ESTABLISHMENT OF A ROLLOVER BANK
ACCOUNT FOR UNENCUMBERED TITLE IV-D CHILD SUPPORT FUNDS
KNOWN AS UNIT COST REIMBURSEMENT FUNDS**

WHEREAS, Jasper County, South Carolina (the “**County**”), a body politic and corporate and a political subdivision of the State of South Carolina (the “**State**”), is organized and governed according to and pursuant to the Constitution and general laws of the State, and has as its governing body the Jasper County Council (the “**County Council**”); and,

WHEREAS, the County receives federal funds through Title IV-D of the Social Security Act for the reimbursement of child support costs and expenses (“**Title IV-D Funds**”); and

WHEREAS, Title IV-D Funds are disbursed and managed pursuant to South Carolina Code 43-5-10 et seq. and South Carolina Code 63-17-10 et seq.; and

WHEREAS, the Title IV-D Funds are disbursed to the Clerk of Court for Jasper County and are placed in a special account and may not be used to replace operating funds of the County budget; and

WHEREAS, pursuant to South Carolina Code 43-5-235, Title IV-D Funds not encumbered for child support services revert to the County general fund at the end of the fiscal year in which they are earned; and

WHEREAS, the County desires to establish the Clerk of Court Roll Over Account for the rollover of prior fiscal year Title IV-D Funds from the County general fund.

NOW, THEREFORE, it is hereby resolved by the Jasper County Council, in meeting duly assembled, that:

1. It is the specific intent of the County Council to enact this Resolution in accordance with, and empowered by, the Constitution and general laws of the State and the Jasper County Code of Ordinances.
2. The County Council approves the establishment of a rollover bank account to manage Title IV-D Funds that are unencumbered at the end of the fiscal year and revert to the general fund.
3. Should any portion of this Resolution be deemed unconstitutional or otherwise enforceable by any court of competent jurisdiction, such determination should not

affect the remaining terms and provisions of this Resolution, all of which are hereby deemed separable.

4. All orders, resolutions and enactments of the County Council inconsistent herewith are to the extent of such inconsistency only, hereby revoked and rescinded.
5. This Resolution shall take effect and be in full force and effect after enactment by the County Council.

RESOLVED this 1st day of June 2026, in a meeting duly assembled.

_____(SEAL)
Joseph Arzillo, Vice Chairman
County Council of Jasper County, South Carolina

ATTEST:

Wanda H. Giles
Clerk to County Council

Resolution R-2026-26
Adopted: June 1, 2026

Reviewed for form and draftsmanship by the interim Jasper County Attorney.

Burr & Forman LLP
Walter J. Nester, III, Partner

Date

AGENDA
ITEM # 9G

**STATE OF SOUTH CAROLINA
JASPER COUNTY**

RESOLUTION NUMBER R-2026-29

RESOLUTION OF JASPER COUNTY COUNCIL

**APPOINTING AN AT-LARGE REPRESENTATIVE TO SERVE ON THE
LOWCOUNTRY COUNCIL OF GOVERNMENT BOARD OF DIRECTORS**

WHEREAS, Jasper County, as a member of the Lowcountry Council of Governments (the “Council”) is authorized pursuant to Article II, Membership and Representation of the Agreement Creating a Regional Council of Governments for the Geographic Area of Beaufort, Colleton, Hampton and Jasper Counties To Be Known as the Lowcountry Council of Governments (the “Agreement”) to appoint five members from Jasper County to the Council, and provide for at least one representative to the appointment category of Jasper County At-Large who is not an elected official from a member county and/or the participating municipality therein; and

WHEREAS; a vacancy now exists on the Lowcountry Council of Government Board of Directors; and

WHEREAS, Jasper County Council has determined that it desires to appoint James G. Williams as the new Jasper County At-Large Board Member Lowcountry Council of Government Board of Directors; and

NOW THEREFORE, BE IT RESOLVED THAT James G. Williams is hereby appointed by Jasper County Council to serve and as the new Jasper County At-Large Board Member Lowcountry Council of Government Board of Directors; and

BE IT FURTHER RESOLVED THAT the terms of this appointment shall be as set forth by the Lowcountry Council of Government.

ADOPTED THIS THE 1st DAY OF June, 2026, and is effective immediately, by Jasper County Council duly assembled.

Resolution #R-2026-29

Joseph Arzillo, Vice Chairman

Attest:

Wanda H. Giles, Clerk to Council

Reviewed for form and draftsmanship by the Jasper County Attorney.

Jasper County Interim Attorney

Date



Serving **Beaufort • Colleton • Hampton • Jasper** Counties

April 16, 2026

Jasper County Council
358 Third Avenue
Ridgeland, SC 29936

Dear County Council:

I'm writing to request the appointment of one Jasper County representative to the Lowcountry Council of Governments Board of Directors.

Appointment category:

- Jasper County At-Large

The At-Large position is to be filled by a representative who is not an elected official from a member county and/or the participating municipality therein. We recommend an active, interested community member for this role.

The board of directors meets on the fourth Thursday bi-monthly at 6:00 pm (February, April, June, August, October, December). Meetings are cancelled when there is no activity requiring board action.

If you have any questions or need any additional information, please contact Debry Thompson, Board Clerk at dthompson@lowcountrycog.org or 843.473.3956 and forward your new appointment information to her as well. Thank you for your attention to this matter.

Sincerely,

Hank Amundson
Executive Director

Lowcountry Council of Governments

PO Box 98 | 634 Campground Road
Yemassee, South Carolina 29945
Main: 843.473.3990 Aging: 843.473.3991 Fax: 843.726.5165
www.lowcountrycog.org

AGENDA

ITEM # 10A

STATE OF SOUTH CAROLINA
COUNTY OF JASPER
Ordinance #O-2026-18
An Ordinance of Jasper
County Council

To provide for the levy of tax for public purposes in Jasper County for the fiscal year beginning July 1st, 2026 and ending June 30th 2027 and to make appropriations for said purposes; to adopt and approve the Jasper County capital and operations budget for fiscal year 2026-2027, to adopt and approve the Jasper County School District capital and operations budget for fiscal year 2026–2027; to provide for the levy of taxation for fiscal year 2026–2027; to limit the disbursements by the county treasurer to those appropriated by law; to provide that expenditures not exceed appropriations; to authorize tax anticipation notes; to make authorization of certain transfers; to provide for additional appropriations and borrowing; to codify Jasper County rates and fees; to provide for lapsing funds and continuing appropriations for subsequent years; to require certain agencies and departments to file accountings; to require the treasurer to sign general fund checks; to provide special rules for travel and training disbursements; to provide for travel reimbursements; to provide compliance with act no. 317 of 1990; to provide certain benefits to council members; to provide for county commission and committee stipends; to provide for jury mileage; to adopt property values; and to provide for effective date of this ordinance, and matters related thereto.

BE IT ORDAINED by the Jasper County Council in council duly assembled and by the authority of the same:

SECTION 1. Appropriation for Jasper County Capital and General Operations Budget. There is hereby appropriated from revenues to be collected from the stated sources the following sums for the Jasper County Capital and Operational needs and for the purposes set forth for fiscal year 2026 – 2027:

**JASPER COUNTY
CAPITAL AND GENERAL OPERATIONS BUDGET
FISCAL YEAR 2026-2027**

REVENUE		EXPENDITURES	
County Property Tax Levy	\$ 50,410,800	Emergency Services	\$ 13,838,795
Local Option Sales Tax	\$ 8,794,000	Sheriff	\$ 12,305,330
Fee in Lieu	\$ 2,375,000	Detention Center	\$ 6,980,775
S.C. Local Government Fund Allocation	\$ 1,490,100	Engineering Services and Solid Waste	\$ 5,631,300
Delinquent Taxes	\$ 1,100,000	Agency Appropriations	\$ 2,201,257
All Other Revenue	<u>\$ 7,371,200</u>	All Other Expenditures	<u>\$ 30,583,643</u>
Total Revenue	\$ 71,541,100	Total Expenditures	\$ 71,541,100
Jasper County Rural Fire District	\$ 3,815,000	Jasper County Fire and Rescue	\$ 3,815,000
County Debt Tax Levy	<u>\$ 1,909,509</u>	County Debt	<u>\$ 1,909,500</u>
County Grand Total	<u>\$ 77,265,609</u>	County Grand Total	<u>\$ 77,265,600</u>

The detailed Operations Budget containing line-by-line accounts by department and /or agency is hereby adopted as part of this Ordinance. Management of individual accounts for the functions of elected officials shall be the responsibility of that elected official.

SECTION 2. Appropriation for Jasper County School District Capital and General Operations Budget. There is hereby appropriated to the School Operations Budget the remaining non-appropriated funds collected through School District ad valorem taxation in Fiscal Year 2025-2026, which were in excess of School District funds appropriated by the FY 2025- 2026 budget ordinance. There is further hereby appropriated from revenues to be collected from the stated sources the following sums for the Jasper County School District Capital and Operational needs and for the purposes set forth for fiscal year 2026 - 2027:

**JASPER COUNTY SCHOOL DISTRICT
CAPITAL AND GENERAL OPERATIONS BUDGET
FISCAL YEAR 2026-2027**

REVENUES

School Property	
Operations Tax Levy	\$ 35,440,400
School Debt	<u>\$ 9,547,500</u>
School Grand Total	\$ 44,987,900

APPROPRIATIONS

School District	
Operations Tax Levy	\$ 35,440,400
School Debt	<u>\$ 9,547,500</u>
School Grand Total	\$ 44,987,900

SECTION 3. Levy. There is hereby levied upon the taxable property of Jasper County a sufficient number of mills by the County Council from assessment of the property therein which, together with fines, forfeitures and taxes collected by various tax offices and all income of the County shall raise the amount therein appropriated and for the purpose herein stated.

	Millage
County Operating	133.000
County Debt	5.000
Jasper County Rural Fire District	25.000
School Operating	164.000
School Debt	<u>25.000</u>
Total Mills	<u>352.000</u>

SECTION 4. Disbursement by Treasurer. The Treasurer is directed to disburse to or on behalf of the activities described in Sections 1 and 2 no more than the amount appropriated and to hold all additional revenues referred to herein and all revenues collected as a result of and through the levied millage, over and above the appropriations stated herein, in an interest bearing account of the County, pending future appropriation by the County Council. In the event that the actual collection of revenue shall be less than the appropriations made in Section 1 or 2, then appropriations shall be reduced to a sum equal to the amount of revenue actually collected.

SECTION 5. Expenditures Not to Exceed Appropriations. Expenditures shall not exceed appropriations without the consent of the County Council. County Council authorization to amend the budget shall be ratified by ordinance through a budget amendment.

SECTION 6. Tax Anticipation Notes Authorized. For the purpose of paying in cash for the foregoing and all other general ordinary County expenses for Fiscal Year 2026-2027 as authorized by this ordinance or by any other appropriation ordinance hereafter passed in and for said fiscal year, the County Council of Jasper County is hereby authorized, empowered, and directed to borrow from time to time as may be necessary on the official note or notes of Jasper County, or other evidence or evidences of indebtedness, in anticipation of the collection of the taxes herein levied, provided that all loans made from private persons, firms, or corporations shall not exceed \$6,000,000 in the aggregate. Such borrowing shall be sold in such manner and upon such terms as the County Administrator shall deem in the best interest of Jasper County, upon the advice of the County's financial advisor and counsel. Such borrowing may take the form of a public or private sale, as deemed appropriate by the Administrator. Such sum or sums so borrowed shall constitute a valid and prior claim against the said taxes herein levied and against Jasper County and shall also be secured by a pledge of the full faith, credit, and taxing power of Jasper County. The Administrator, and any other officers or staff of Jasper County as are deemed by the Administrator necessary or convenient to the accomplishment of the borrowing authorized herein, are hereby authorized to execute all agreements, contracts, certificates, undertakings, disclosures, and other documentation as is convenient or necessary to facilitate such borrowing.

SECTION 7. Authorization of Transfer of Funds. Each department head is permitted, subject to the County Administrator's (or his designee's) approval, to transfer appropriation(s) between object classifications codes within that department. Transfers from objects 2000 through 2080 (personnel codes) are not permitted under any circumstances without the approval of the County Administrator. The County Administrator is permitted, when it is in the best interest of the individual County departments or agencies, to transfer appropriations between departments (from one department to another department) and between the County's General Fund, Capital Projects Fund and Capital Improvements Fund (from one fund to another fund up to \$50,000).

SECTION 8. Additional Appropriations and Borrowing. If circumstances arise which, in the judgment of a majority of County Council, require the expenditure of a greater amount than herein above enumerated then the County Administrator shall have and is hereby given the right by this Ordinance to transfer funds between the County's General Fund, Special Revenue Funds, and Capital Projects Funds and may also appropriate available funds for a purpose not mentioned or referred to in this Ordinance, and the County Treasurer is authorized to borrow, if necessary, such amount as may be required to meet such increases or additional appropriations and may pledge the full faith and credit of Jasper County for the payment of the amount borrowed. Should actual funding sources be greater than projected in this Ordinance, the County Administrator may revise budgeted revenues and expenditures or direct the increase to be held for future year's disbursements.

SECTION 9. Jasper County Rates and Fees. The rates and fees attached hereto that are not included or provided for by either South Carolina law or other Jasper County law shall

hereby be declared to be part thereof this Ordinance and shall be followed during implementation of the Fiscal Year 2026-2027 Budget for Jasper County.

SECTION 10. Lapsing of Funds and Continuing Appropriations for Subsequent Year.

Budget appropriations of monies received by County departments and existing at the close of the fiscal year shall revert to the appropriate fund of the County. Departments wishing to carry over appropriations into the next succeeding fiscal year must submit the request in writing to the County Administrator no later than August 1, 2026, for approval by the County Council. These carryovers must be for specific items budgeted in the 2025 - 2026 fiscal year for which unforeseen circumstances prevented the funds from being spent during the current year. Any “excess” funds accumulated at the end of the fiscal year shall be used only with the approval of County Council either to fund capital assets or other expenditures needed by the County or placed in the appropriate reserve fund by the County Administrator. Departments charged with the proper keeping and reporting of County accounts shall maintain both revenue and expenditure ledgers, and under no circumstances, except in such instances as over-payment errors, authorized transfers, or supplemental appropriations, shall entries except those enumerated in this Ordinance, be recorded on appropriations and/or expenditure ledgers.

Should the County Council in any subsequent year fail to enact an appropriation ordinance for Jasper County, the appropriation and tax levy herein set forth shall be the appropriation ordinance for such subsequent year for Jasper County.

SECTION 11. Agencies and Departments to File Accounting.

Agencies or departments receiving appropriated funds under this ordinance, at the County Council’s request, shall file an accounting for use of such funds. This accounting shall be available for examination or inspection by the citizens of Jasper County.

SECTION 12. Treasurer to Sign Checks.

The Jasper County Treasurer or the Treasurer’s designee shall sign all general fund checks.

SECTION 13. Special Rules for Travel and Training Disbursements.

The elected officials, appointed officials and/or department heads who receive an annual appropriation for travel and training shall be required to present an itemized statement and all appropriate receipts for reimbursement of the same. No official or department head shall be reimbursed in excess of their annual appropriation unless such expenditures are approved in advance by the County Administrator.

SECTION 14. Travel Reimbursements.

All Jasper County employees who have reason to travel outside of Jasper County on official County business shall be reimbursed for same with respect to the County mileage rate and the latest approved subsistence schedule both of which are published in the Jasper County Personnel Policies and Procedures Manual. All out of state travel must be approved in advance by the County Administrator.

SECTION 15. Compliance with Act No. 317 of 1990.

Section 1 of the Fiscal Year 2026–2027 Budget Ordinance contains provisions for the rollback against County property tax

of \$5,892,000 of local option sales tax revenue for the fiscal year 2025-2026, and \$1,076,900 carry-forward from fiscal year 2024. The \$6,968,900 meets or exceeds the amount required as rollback in Act No. 317, 1990 Acts and Joint Resolutions 1822. All other local option tax discount revenue shall become general fund expenditures, as budgeted in the Fiscal Year 2026-2027 Budget. The local option sales tax discount factor for Fiscal Year 2026-2027 shall be .0007 which determines the amount of discount on individual tax bills. The factor was determined by using the formula prescribed by Act No. 317, 1990 Acts and Joint Resolutions 1822.

SECTION 16. Council Member Benefits. The Council Members wishing to be on the County Health Insurance Plan may do so under the same guidelines as the other County employees. Council Members, who do not choose to be on the County's Health Insurance Plan, may be compensated with additional benefits not to exceed the value of a County employee's health insurance benefit paid by the County. Additional benefits that may be offered in lieu of health insurance include, but are not limited to, life insurance, dental insurance, existing 401K, new 401K accounts, existing IRA accounts or new IRA accounts, deferred compensation and credit union. These benefits will be limited to those plans already in place by the County and the County Administrator will have full discretion as to which benefits are offered. These benefits may not be exchanged for monetary compensation under any circumstances.

SECTION 17. Commission and Committee Stipends. This budget ordinance limits the payment of stipends to members of the Jasper County Planning Commission to one stipend per month in the amount of \$100.00. These stipends shall be paid providing the member attends the scheduled meeting. A quorum of the committees must be in attendance at the scheduled meeting for the stipend to be paid. The Board of Assessment Appeals and the Board of Zoning Appeals members will be paid an annual stipend of \$500.00.

SECTION 18. Juror Mileage. The Clerk of Court is hereby authorized and required to reimburse jurors for mileage for each day's attendance upon court at the current Internal Revenue Service published rate for mileage.

SECTION 19. Property Values Adopted. The property values established by the County Auditor, County Assessor and the South Carolina Department of Revenue, based on Dec. 31, 2025, valuation are adopted and ordered implemented for tax year 2026.

SECTION 20. Effective Date. This ordinance shall take effect on July 1, 2026.

Jasper County Council

BY: _____
Joseph Arzillo, Vice Chairman

ATTEST:

Wanda H. Giles, Clerk to County Council

First Reading: 5/18/2026
Second Reading: 6/1/2026
Public Hearings:
Adopted:

Reviewed for form and draftsmanship by the Jasper County Attorney.

Jasper County Attorney

Date

AGENDA

ITEM # 10B

Consideration of the **1st Reading** by **TITLE ONLY** of an Ordinance to Provide for the Issuance and Sale of not Exceeding Two Million Dollars (\$2,000,000) Aggregate Principal Amount of General Obligation Bonds of Jasper County, South Carolina in one or more series, to Prescribe the Purposes for which the Proceeds Shall Be Expended, to Provide for the Payment Thereof, and to Provide for Other Matters Related Thereto.

AGENDA

ITEM # 10C



Jasper County Planning and Building Services

358 Third Avenue - Post Office Box 1659
Ridgeland, South Carolina 29936
Phone (843) 717-3650 Fax (843) 726-7707

Hunter Smiley
Planner
hsmiley@jaspercountysc.gov

Jasper County Council Staff Report

Meeting Date:	June 1, 2026
Project:	Zoning Map Amendment – Rural Preservation
Applicant:	Hoota Woods Plantation LLC.
Tax Map Number:	052-00-10-013
Submitted For:	1 st Reading
Recommendation:	Planning Commission recommends Rural Preservation

Description: This is a zoning map amendment request to have a parcel designated as Rural Preservation. The subject property consists of 312.43 acres and is located off Hoota Woods Plantation Road. The parcel is currently split zoned Residential and Rural Preservation. The owners purchased the property with the intent for it to one day be a commercial agricultural operation (growing sugar cane & making cane syrup). In 2019, the owners purchased a neighboring 12-acre parcel that was zoned as residential and abandoned the lot lines so that it could be one combined parcel. The owners would like to acquire a business license for their proposed commercial agricultural operation but cannot acquire a zoning certificate due to the parcel being split zoned and the agricultural use not being permitted within the residential zoning district. The zoning map amendment would allow the applicant to obtain a business license and establish their farming business.

Analysis: The Zoning Map Amendment application and request are reviewed by considering the following factors:

- **Comprehensive Plan:** According to the 2018 Jasper County Comprehensive Plan, the Future Land Use Map identifies this area as “Rural Conservation,” which are areas that seek to protect and promote the character of Jasper County that largely exists today outside of the municipalities. Most development, especially commercial development, should be guided to the hamlets.
- **Adjacent Zoning:** The adjacent parcels are zoned Rural Preservation and Residential.

- ***Adjacent Land Use:*** Adjacent land uses are agricultural and residential.
- ***Traffic and Access:*** The subject parcel is accessed by Stella Cleland Road, which is a two-lane county-maintained road classified as a local road. There is also a road that goes through the parcel, which is Hoota Woods Plantation Road, a private maintained road.

Planning Commission Recommendation: Planning Commission recommends approval of the request to designate the subject parcel as Rural Preservation.

Attachments:

1. Application
2. Ordinance
1. Aerial zoning map
2. Aerial satellite image map



Jasper County Planning Department

358 Third Avenue - Post Office Box 1659
 Ridgeland, South Carolina 29936
 Phone (843) 717-3650 Fax (843) 726-7707

Zoning Map Amendment Application

Owner or Owner-Authorized Applicant:	Hoot Woods Plantation LLC
Address:	2 Means Bluff Way Sheldon, SC 29941
Telephone:	843-846-6088
Email:	info@midas-advisors.com
Property Address or Physical Location:	606 Hoota Woods Plantation Road Early Branch, SC 29916
Tax Map Number(s)	05-00-10-013 <i>2</i>
Gross Acreage:	312.43
Current Zoning	Split - Residential & Rural Preservation
Proposed Zoning:	Rural Preservation
Administrative Fee: (\$300 per lot) except for PDD applications	\$300.00
Date Mailed or Hand Delivered:	April 15, 2026
Reason for Request: (attach narrative if necessary)	To correct and conform Zoning for unified rural preservation land holding

4-15-26

Signature of Owner or Owner-Authorized Applicant Date
 (Proof) of owner-authorization required)

Internal Use Only

Date Received:	<i>4-15-26</i>
Amount Received:	<i>\$300.00</i>
Staff Member:	<i>Kenzie Stone</i>

**STATE OF SOUTH CAROLINA
COUNTY OF JASPER**

ORDINANCE #2026-____

AN ORDINANCE OF JASPER COUNTY COUNCIL

TO AMEND THE OFFICIAL ZONING MAP OF JASPER COUNTY BY REZONING THAT CERTAIN PARCEL OF REAL PROPERTY LOCATED ALONG HOOTA WOODS PLANTATION ROAD, BEARING JASPER COUNTY TAX MAP NUMBER 052-00-10-013 CONSISTING OF 312.43 ACRES FROM THE RESIDENTIAL DISTRICT (R) AND RURAL PRESERVATION DISTRICT (RP) TO THE RURAL PRESERVATION DISTRICT (RP).

WHEREAS, Jasper County, South Carolina (the “**County**”), acting through the Jasper County Council as its governing body (the “**County Council**”), is a political subdivision of the State of South Carolina (the “**State**”), and as such possesses all the general powers granted by the Constitution and statutes of the State to such public entities; and

WHEREAS, Hoota Woods Plantation LLC is the owner of a parcel of real property (the “**Owner**”) consisting of approximately 312.43 acres bearing Jasper County Tax Map Number 052-00-10-013 and located along Hoota Woods Plantation Road (the “**Property**”); and

WHEREAS, Owner has requested the rezoning of the Property and an amendment to the Official Zoning Map of Jasper County (the “**Zoning Map**”) from the “Rural Preservation District and Residential District” to the “Rural Preservation District” (the “**Application**”); and

WHEREAS, the Owner submitted its request to the Jasper County Planning Commission and Jasper County Council in accordance with the County’s ordinances, regulations, rules and procedures for rezoning and amending the Zoning Map; and

WHEREAS, the Jasper County Planning Commission has concurred with the recommendations of the County staff report concerning the Application as reflected in this Ordinance and recommends approval by Jasper County Council; and

WHEREAS, this matter is now before the Jasper County Council for determination.

NOW THEREFORE BE IT ORDAINED, by the Jasper County Council in council duly convened and by the authority of the same:

1. Jasper County Council finds that in accordance with the staff report and the recommendation of the Planning Commission, the proposed zoning is consistent with the continued pattern of growth in the vicinity and is compliant with the Jasper County Comprehensive Plan. Good cause having been shown, the Property consisting of approximately 312.43 acres bearing Jasper County Tax Map Number 052-00-10-013 and the Jasper County Official Zoning Map from the Residential District and Rural Preservation District, shall hereby be rezoned to the Rural Preservation District.
2. This ordinance shall take effect upon approval by Jasper County Council.

Joseph Arzillo, Vice Chairman

ATTEST:

**Wanda Giles
Clerk to Council**

ORDINANCE 2026 - _____
First Reading: 6-1-2026
Second Reading: _____
Public hearing: _____
Adopted: _____

Considered by the Jasper County Planning Commission at its meeting on
May 12, 2026 and recommended for approval.

Reviewed for form and draftsmanship by the interim Jasper County Attorney.

Interim County Attorney
Burr & Forman LLP

By: _____
Walter J. Nester, III
Partner

_____ **Date**

- Layer List Legend
- Quick Links:
- Property Search
 - View Map
- Layers:
- Parcels
 - Parcel Numbers
 - 911 Address Points (red)
 - Yearly Sales
 - Subdivisions
 - USA Major Highways
 - Roads
 - Town Limits
 - Railroads
 - Hardeeville Zoning
 - Ridgeland Zoning
 - Ridgeland Airport
 - Streams and Rivers
 - Wetlands
 - County Outlines
 - Jasper Zoning
 - Effective FEMA Flood Layer 7/3/2025
 - Previous FEMA Flood Layer
 - Flood Zones
 - 2016 Aerial Photos
 - 2020 Aerial Photos
 - 2024 Aerial Photos
- [Restore Layer Defaults](#)

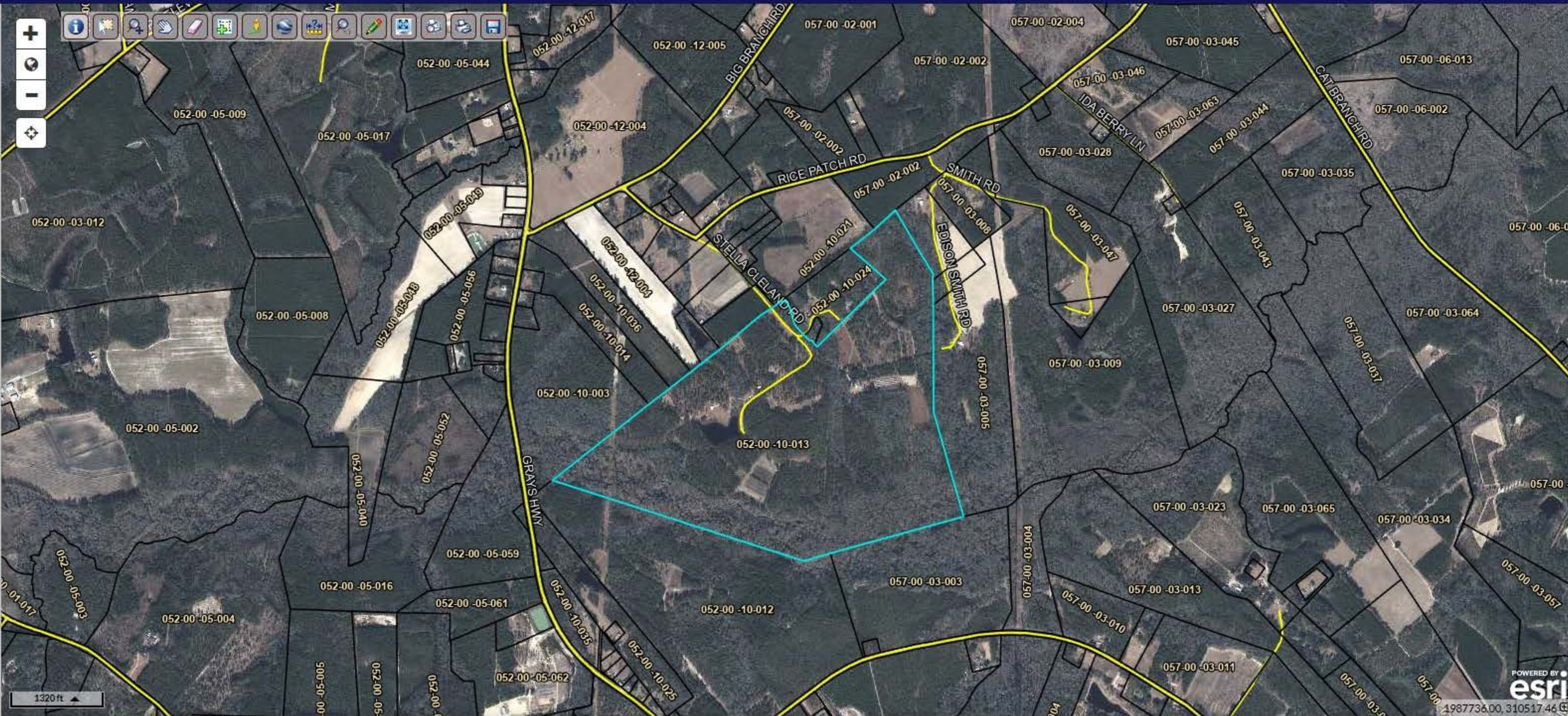

Results:

Parcel ID - 052-00-10-013
 Alt Id - 052-00-10-013
 Address - 606 HOOTA WOODS PLANT RD
 Owner - HOOTA WOODS PLANATATON LLC
 Acres - 312.43
[View Report](#) | [Apply for Permit](#) | [Google Maps](#)

Parcel ID 052-00-10-013
 Sec/Twp/Rng n/a
 Property Address 606 HOOTA WOODS PLANT RD

Alternate ID 052-00-10-013
 Class Rural single family residence (not legal)
 Acreage 312.43

Owner Address HOOTA WOODS PLANATATON LLC
 2 MEANS BLUFF WAY
 SHELDON, SC 29941

Last 2 Sales

Date	Price	Reason	Qual
8/14/2019	0	n/a	U
n/a	0	n/a	n/a

District 01
 Brief Tax Description n/a
 (Note: Not to be used on legal documents)



Layer List Legend

Quick Links:

- Property Search
- View Map

Layers:

- Parcels
- Parcel Numbers
- 911 Address Points (red)
- Yearly Sales
- Subdivisions
- USA Major Highways
- Roads
- Town Limits
- Railroads
- Hardeeville Zoning
- Ridgeland Zoning
- Ridgeland Airport
- Streams and Rivers
- Wetlands
- County Outlines
- Jasper Zoning
- Effective FEMA Flood Layer 7/3/2025
- Previous FEMA Flood Layer
- Flood Zones
- 2016 Aerial Photos
- 2020 Aerial Photos
- 2024 Aerial Photos

[Restore Layer Defaults](#)



Results:

Parcel ID - 052-00-10-013
 Alt Id - 052-00-10-013
 Address - 606 HOOTA WOODS PLANT RD
 Owner - HOOTA WOODS PLANATATON LLC
 Acres - 312.43
[View Report](#) | [Apply for Permit](#) | [Google Maps](#)

Parcel ID	052-00-10-013	Alternate ID	052-00-10-013	Owner Address	HOOTA WOODS PLANATATON LLC	Last 2 Sales			
Sec/Twp/Rng	n/a	Class	Rural single family residence (not legal)		2 MEANS BLUFF WAY	Date	Price	Reason	Qual
Property Address	606 HOOTA WOODS PLANT RD	Acres	312.43		SHELDON, SC 29941	8/14/2019	0	n/a	U
District	01					n/a	0	n/a	n/a
Brief Tax Description	n/a								

(Note: Not to be used on legal documents)

AGENDA

ITEM # 10D



Jasper County Development Services Department

358 Third Avenue
Ridgeland, South Carolina 29936
Phone (843) 717-4119

Name: Eric W. Larson
Title: Development Services Director
Email address: ewlarson@jaspercountysc.gov

Jasper County Council Staff Report

Meeting Date:	June 1, 2026
Agenda Item:	Item 10-D
Request:	Consideration of awarding bid to Lorick Office Products to upfit furniture for the Development Services Department and Code Enforcement Department, at a cost of \$52,983.33 and authorize the Administrator to finalize the purchase.
Action Needed:	County Council to approve new furniture to upfit the Development Services Department and Code Enforcement Department.
Recommendation:	Staff recommends County Council approve the purchase of office furniture for the Development Services Department and Code Enforcement Department in the amount of \$52,983.33 and authorize the County Administrator to execute all necessary purchasing documents.

Description: The proposed office renovation and furniture purchase will create a new workspace for the Development Services Department and Code Enforcement Department within the area currently occupied by the Assessor's Office. The new layout will include six cubicle workstations with desks, as well as office furniture for the Development Services Director's office. The updated space is intended to improve departmental organization, staff functionality, and operational efficiency while providing a professional and functional work environment for employees and the public.

Staff Recommendation: Staff recommends County Council approve the purchase of office furniture for the Development Services and Code Enforcement Departments in the amount of \$52,983.33 and authorize the County Administrator to execute the necessary documents.

Attachment(s): Lorick Office Products final quote.

Lorick Office Products

Quotation

910 Washington Street
 Columbia, SC 29201
 Phone 803.252.5380 Fax 803.799.2342

DATE 5.20.26
Quotation # 514.2
Customer ID 1791

Bill To:
 Ms. Mandy Williams
 Jasper County - Development Services

Quotation valid until: 30 Days
Prepared by: D. Southern

Comments or Special Instructions:

Qty	Part #	Description	State \$ Ea	Extended
State Contract - Hon - # 4400022602				
Cubicles				
1	Lot A	Workstations, 6.5' x 8' See Attached Parts List Line 1-39	\$ 31,947.00	\$ 31,947.00
Eric's Office				
1	Lot B	U Station, Round Table See Attached Parts List Line 40-52	\$ 5,278.11	\$ 5,278.11
Conference Room				
1	Lot C	8' Table, Rectangular See Attached Parts List Line 53-54	\$ 991.27	\$ 991.27
State Contract - Exemplis, Sit on It - # 4400022816				
Seating				
1	Lot D	10 Conference Chairs, Guest, Arms, Casters 4 Guest Chairs, Guest, Arms, No Casters 7 Task Chairs, Arms	\$ 7,777.50	\$ 7,777.50
Subtotal - State Contract Extended				\$ 45,993.88
Sales Tax @ 9%				\$ 4,139.45
Design and Installation				\$ 2,850.00
Grand Total				\$ 52,983.33

All items listed above are considered special order and non-returnable. Pricing shown is discounted per manufacturer. Design and installation, if applicable, is quoted separately per order. An order constitutes agreement to these terms and conditions.

Thank you for this opportunity to serve you!

Lorick Office Products
Confidential

AGENDA

ITEM # 10E



Jasper County Clerk of Court

Post Office Box 248 • Ridgeland, South Carolina 29936

Phone: (843) 726-7710 • Fax: (843) 726-7711

R. Keith Horton
Clerk of Court

Jasper County Council,

The Clerk of Court is requesting approval for the purchase of two (2) X-ray bag scanners to enhance safety and security in the courthouse and the administration building.

Public county offices and the county courthouse are high-traffic environments, and this equipment allows security to quickly and efficiently detect prohibited or dangerous items while maintaining smooth daily operations. It helps protect our staff, judiciary, law enforcement, and the public.

This recommendation comes from courthouse security professionals and aligns with what has already become standard in many counties similar to ours.

To fund this, I am recommending we move prior years' Title IV-D unit cost funds into a **Clerk of Court line item**. This will allow us to make this purchase and address future security needs without increasing taxes on our citizens.

This is a proactive investment in safety, using existing resources responsibly.

Thank you for your consideration.

Robert K. Horton, Clerk of Court

A SAFER COURTHOUSE: IMPLEMENTING BAG SCANNER TECHNOLOGY

Jasper County Clerk of Court



IMPORTANCE OF BAG SCANNERS

- Enhances overall courthouse security for staff, visitors, and law enforcement
- Detects weapons, contraband, and other prohibited items before entry
 - Helps prevent potential threats and dangerous incidents
- Supports deputies by reducing reliance on manual bag searches
 - Speeds up and organizes the screening process at entrances
- Maintains a safe environment for sensitive and high-risk court proceedings
 - Increases public confidence in courthouse safety and operations
- Ensures compliance with standard security protocols and best practices

OPTION 1: SECURITY PRO USA

5333 DVS AUTOCLEAR X-RAY SCANNER (160KV)

INCLUDES	APPLICATIONS
Archiving/Storage to USB	Passenger, Staff, and Visitor Checkpoint Inspection
Built-In Training	Corporate, Government and Private Security
AutoNet Imaging / Touch Pad Operation	Critical Infrastructure Security

5333DVS X-RAY INSPECTION

Performance, Precision and Control



X-RAY INSPECTION



Model 5333DVS X-Ray Inspection System

Designed for screening and sized items for weapons, explosives, drugs and other items around the single source, multi-energy 5333DVS X-Ray inspection system is fast and easy to operate. Ideal for screening hand carried items such as pistols, briefcases, backpacks, strollers, small jewelry and more, the compact 5333DVS is a great choice for small air terminal gates. The system's low profile, built-up generator design makes smaller items appear much sharper and larger on screen.

- 1) Rapidly adjusts full multiple and turn or tilt arms
- 2) Fits in corridors, narrow halls and tight spaces
- 3) Patented guided arm design sets screen needs adjusting
- 4) Built on the industry's most rugged and flexible mounting system
- 5) Two generator power levels to choose from (see back for details)

APPLICATIONS

- 1) Screening of passengers
- 2) Screening of baggage
- 3) Screening of mail
- 4) Screening of cargo
- 5) Screening of vehicles
- 6) Screening of containers
- 7) Screening of mail
- 8) Screening of cargo
- 9) Screening of mail
- 10) Screening of cargo
- 11) Screening of mail
- 12) Screening of cargo
- 13) Screening of mail
- 14) Screening of cargo
- 15) Screening of mail
- 16) Screening of cargo
- 17) Screening of mail
- 18) Screening of cargo
- 19) Screening of mail
- 20) Screening of cargo

Model 5333DVS X-Ray Inspection System

Description	Qty	UOM	Cost	Total
Model 5333DVS AutoClear X-Ray Inspection System (150Kv) including 1 hour 15 minute Full Operation, 150Kv APS, Image Archiving Storage w/ 1 Yr. Backup Image, AutoMail, Management Program Empty Exam/Reel Hold 7' (std) Queue Training and Installation Case - 1 height	1		19,706.00	19,706.00
	1		1,500.00	1,500.00
	1		1,550.00	1,550.00
	1		1,700.00	1,700.00
Crash Parts Direct Phone 310-475-7780 Ext. 109 Fax 310-475-7063 www.securepima.com sp@securepima.com P/N: 616679019 Federal Tax ID: 95-4108368 CAGE: 2838D C31: 23816797CAQ5 Small Business GSA Contract #GS-07-04771 Sales Tax			0.00%	0.00
Total				\$24,256.00

OPTION 2: PROTECTIVE TECHNOLOGIES INTERNATIONAL

4535DVS AUTOCLEAR X-RAY SCANNER (90KV)

INCLUDES	APPLICATIONS
Archiving/Storage to USB	Mail Screening
AutomAlert (Threat Identification Program)	Executive Offices
Linux OS (Touch Pad Operation)	Private, Diplomatic, High-risk Event Security



Protective Technologies International

3450 Triumph Blvd, #102
Lehi, Utah 84043 USA
8012809997
sales@pti-world.com
www.pti-world.com

Quote

ADDRESS

Robert Horton
Jasper County

SHIP TO

Robert Horton
Jasper County

QUOTE # 250929-21

DATE 10/14/2025

ITEM	DESCRIPTION	QTY	RATE	AMOUNT
Autoclear 4535	Model 4535DVS AutoClear X-ray Scanner (90Kv) Including: - Linux OS (Touch Pad Operation) - AutomatAlert (Threat Identification Program) - Image Archiving/Storage (USB) - User Management	1	15,875.00	15,875.00
Shipping	Shipping	1	2,500.00	2,500.00
Other Install & Training	Installation and Training	1	3,500.00	3,500.00

PAYMENT TERMS (USD)

- 50% due upon estimate approval and invoice
- Balance due prior to shipping (typically 3-6 weeks)

TOTAL

\$21,875.00

**PLEASE READ ATTACHED TERMS AND
CONDITIONS!**

*Approval of this quote digitally, verbally, or by email
implies you have read and agree to the attached terms
and conditions.

Accepted By

Accepted Date

Thank You for Your Business

4535DVS X-RAY INSPECTION

Explosives, Weapons and Contraband



SINGLE SOURCE, MULTI-ENERGY

X-RAY INSPECTION



Lighter and shorter than our best-selling full-size scanner, the 4535DVS packs all the speed, power and detection capability of our flagship multi-energy models into a sub-compact design. Sized for inspecting mail, hand carried objects, personal items, clothing and shoes, the 4535DVS meets the throughput demands of high-traffic settings. An intuitive operator interface makes this unit suitable for both security professionals and non-technical personnel.

- > The performance and features of larger, heavier systems in a compact cabinet design
- > Fits through narrow doorways and in standard elevators
- > Easy to use operator interface
- > Full suite of image enhancement tools

APPLICATIONS:

- > Mail Screening
- > Executive Offices
- > Private Security
- > VIP and Diplomatic Security
- > High-risk Event Security

4535DVS SPECIFICATIONS

PHYSICAL DETAILS

Tunnel Size:	47.0 x 35.0 cm 18.5 x 13.8 in. (W x H)
Overall Dimensions:	85.5 x 66.4 x 107.5 cm 33.7 x 26.2 x 42.3 in. (L x W x H)
Weight:	273 kg (602 lbs.) uncrated 315 kg (694 lbs.) crated
Construction:	Robust heavy gauge, epoxy-painted, steel frame construction. Stainless steel and aluminum trim and accessories. Non-marking casters.
Temperature:	Operating: 0° to 40° C (32° to 104° F) Storage: -20° C to 60° C (-4° to 140° F)
Humidity:	20%-95%, non-condensing
System Power:	115/230 VAC +/- 10% 60/50 Hz 0.7 kVA max

X-RAY GENERATOR

X-ray Tube Head:	Self-contained with sealed oil bath cooling
High Voltage Rating:	100 kV, operating at 90 kV
Duty Cycle:	100%
Beam Orientation:	Diagonal (80° beam divergence)
Dose per Exam:	<0.1mR; <i>May be higher or lower due to differing combinations of kV level & X-ray beam configuration</i>
Radiation Leakage:	<0.5mR/hr (<5.0µSv/hr); <0.1mR/hr (<1.0µSv/hr) available

INSPECTION CAPABILITIES

Material (steel) Penetration:	10 mm guaranteed (11 mm typical)
Contrast Sensitivity:	Over 2 million color tones standard
Resolution (wire):	38 mm guaranteed (40 AWG typical)
Processing:	At least: 32-bit adaptive image processing with minimum 2 Gbytes+ memory; 2.2 GHz+ dual core processor; video processing using next generation graphical processing unit architecture with 550MHz+ GPU clock, 512Mbyte+ video memory and 32+ stream processing cores
Conveyor Speed:	24.0 cm (9.4 in.) per second 14.6 m (48 ft.) per minute
Pulling Weight:	150 kg (331 lbs.)
Film Safety:	Guaranteed for high-speed film up to ISO 1600 (33 DIN)

DETECTORS

High-speed, ultra-sensitive photodiode detector array; L-shaped for 100% package screening

VIDEO

19" Color LCD monitor, 1280 x 1024 video card

STANDARD FEATURES

- autoCal
- autoDensAlert
- autoImage recall (10 images)
- autoOutline
- autoScale
- autoSensing
- autoSoft (LINUX) operating system
- autoTracking guided conveyor belt
- 128x Smart Zoom
- Adjustable zoom preview window
- Color; reverse B/W imaging
- Dark and light enhance
- Entrance tunnel extension
- Exit tunnel extension
- Full-sized operator control panel (OCP) with touchpad navigation
- High/Low Density and Stripping
- Interactive help screens
- Organic / Inorganic
- RealClear
- Real-Time Diagnostics
- Save screen to USB

OPTIONS

- autoArchive
- autoShieldAlert
- autoZ display
- Built-in training
- CE/CSA/US safety/EMC certification
- Console desk
- Conveyor extensions
- Dual monitors
- DVD drive
- Exit tunnel extension
- Footpad
- Image archiving (500K)
- Image export in BMP & JPG
- Item counter
- kV, mA meter
- Larger monitors (1920x1080 res.)
- Laser printer
- Loading or exit rollerbeds
- Locking metal OCP cover
- Locking monitor garage
- Monitor platform
- Networking:
 - autoNet Live View
 - Remote Diagnostics
 - Remote Image Review
 - Remote Management
- Optical X-ray on/off sensor
- Parcel slide
- Power conditioner or UPS
- Remote operation
- Sharp Scroll
- Tropical humidity kit
- User management
- Variable height OCP mount
- X-ray image viewer software

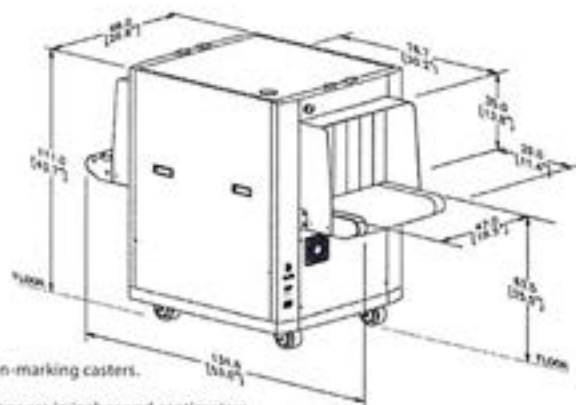

Note: Non-marking casters.

Dimensions are in inches and centimeters.



World Headquarters
10A Bloomfield Avenue
Pine Brook, NJ 07058 USA

Tel. +1 973.276.6000
+1 973.276.6161
Fax. +1 973.227.0832

www.autoclear.com

info@autoclear.com

HEALTH & SAFETY

Complies with US FDA, Chapter 1 Department of Health and Human Services, Subchapter J Radiological Health, Performance Standards for Ionizing Radiation Emitting Products, 21 CFR 1020.40 Cabinet X-ray Systems.

ISO 9001:2015 REGISTERED

2011-2019 © Autoclear, CheckGate®, Control Screening®, Dynamsoft®, X-rayShield® and Scintex® are among our many registered trademarks. All rights reserved.
500A0017 - Spec Sheet 4535DVS - initial - 09.26.2019



Security Pro USA

310-475-7780
 www.securityprousa.com
 8543 Venice Blvd
 Los Angeles, CA 90034

Quote

Date	Quote #
10/14/2025	2250

Name / Address
Jasper County Clerk of Court Robert Horton 8434769570 rkhorton@jaspercountysc.gov

Rep	Project
CP.	

Description	Qty	U/M	Cost	Total
Model 5333DVS AutoClear X-Ray Scanner (160Kv) Including: Linux OS (Touch Pad Operation), AutoMat Alert, Image Archiving/Storage to USB, Built-In Training, AutoNet 1, Image Management Program	1		19,706.00	19,706.00
Entry/Exit Roller Beds 3' (set)	1		1,300.00	1,300.00
Onsite Training and Installation	1		1,550.00	1,550.00
Crate + Freight	1		1,700.00	1,700.00
Cindy Perez Direct Phone: 310-475-7780 Ext. 109 Fax: 310-475-7065 cp@securityprousa.com www.securityprousa.com DUNS# 616679049, Federal Tax ID: 95-4308568 CAGE: 3R0M2 UEI: E2RHG9EPXAQ5 Small Business/GSA Contract #GS-07F-0577T Sales Tax			0.00%	0.00
Total				\$24,256.00

Export warning : This product may be subject to the Arms Export Control Act (Title 22, U.S.C., Sec 2751, et seq.). Violations of these export laws are subject to severe criminal penalties. US export controls and may fall under ITAR or BIS regulations. It is the buyer

5333DVS X-RAY INSPECTION

Explosives, Weapons and Contraband



SINGLE SOURCE, MULTI-ENERGY

X-RAY INSPECTION



Shown with optional tunnel extensions.

Designed for screening mid-sized items for weapons, explosives, drugs and other contraband, the single-source, multi-energy 5333DVS X-ray inspection system is fast and easy to operate. Ideal for screening hand carried items such as purses, briefcases, backpacks, strollers, small parcels and more, the compact 5333DVS is a great choice for small and limited spaces. The system's low profile, bottom-up generator design makes smaller items appear much sharper and larger on-screen.

- > Rapidly images full mailbags and long or tall items
- > Fits in elevators, narrow halls and tight spaces
- > Patented guided conveyor belt never needs adjusting
- > Built on the industry's most stable and flexible operating system
- > Two generator power levels to choose from (see back for details)

APPLICATIONS:

- > Passenger, Staff and Visitor Checkpoint Inspection
- > Corporate, Government and Private Security
- > Critical Infrastructure Security
- > Mail Screening

5333DVS SPECIFICATIONS

PHYSICAL DETAILS

Tunnel Size:	53.0 x 33.1 cm 20.8 x 13.0 in. (W x H)
Overall Dimensions:	133.2 x 74.0 x 112.2 cm 52.4 x 29.1 x 44.3 in. (L x W x H)
Weight:	100 kV: 275 kg (606 lbs.) Net weight 328 kg (723 lbs.) Shipping weight 160 kV: 333 kg (734 lbs.) Net weight 380 kg (838 lbs.) Shipping weight
Construction:	Robust heavy gauge, epoxy-painted, steel frame construction. Stainless steel and aluminum trim and accessories. Non-marking casters.
Temperature:	Operating: 0° to 40° C (32° to 104° F) Storage: -20° C to 60° C (-4° to 140° F)
Humidity:	20%-95%, non-condensing
System Power:	115/230 VAC +/- 10% 60/50 Hz 0.7 kVA max

X-RAY GENERATOR

X-ray Tube Head:	Self-contained with sealed oil bath cooling
High Voltage Rating:	100 kV, operating at 90 kV (standard) or 160 kV, operating at 140 kV (optional)
Duty Cycle:	100%
Beam Orientation:	Diagonal (80° beam divergence)
Dose per Exam:	<0.1mR; <i>May be higher or lower due to differing combinations of kV level & X-ray beam configuration</i>
Radiation Leakage:	<0.5mR/hr (<5.0µSv/hr); <0.1mR/hr (<1.0µSv/hr) available

INSPECTION CAPABILITIES

Material (steel) Penetration:	10 mm guaranteed (11 mm typical) with 100kV 28 mm guaranteed (29 mm typical) with 160 kV
Contrast Sensitivity:	Over 2 million color tones standard
Resolution (wire):	38 mm guaranteed (40 AWG typical)
Conveyor Speed:	24.0 cm (9.4 in.) per second 14.6 m (48 ft.) per minute
Pulling Weight:	160 kg (352 lbs.)
Film Safety:	Guaranteed for high-speed film up to ISO 1600 (33 DIN)

DETECTORS

High-speed, ultra-sensitive photodiode detector array;
L-shaped for 100% package screening

VIDEO

19" Color LCD monitor, 1280 x 1024 video card

STANDARD FEATURES

- autoCal
- autoDensAlert
- autoImage recall (10 images)
- autoOutline
- autoScale
- autoSensing
- autoSoft (LINUX) operating system
- autoTracking guided conveyor belt
- 128x Smart Zoom
- Adjustable zoom preview window
- Color; reverse B/W imaging
- Dark and light enhance
- D-SCAN with 160 kV only
- Entrance tunnel extension
- Exit tunnel extension
- Full-sized operator control panel (OCP) with touchpad navigation
- High/Low Density and Stripping
- Interactive help screens
- Organic / Inorganic
- RealClear
- Real-Time Diagnostics
- Reversible conveyor direction
- Save screen to USB
- Z-SCAN with 160 kV only

OPTIONS

- autoColor+ with 160 kV only
- autoMatAlert
- autoShieldAlert
- autoZ display
- 160 kV generator, operating at 140 kV
- Built-in training
- CE/CSA/US safety/EMC certification
- Console desk
- Conveyor Extensions
- Dual monitors
- DVD drive
- Footpad
- Image archiving (500K)
- Image export in BMP & JPG
- Item counter
- kV, mA meter
- Larger monitors (at least: 24", HD flicker-free LCD; 1920x1080 res.)
- Laser printer
- Loading or exit 18" parcel slide
- Loading or exit rollerbeds
- Locking metal OCP cover
- Locking monitor garage
- Monitor platform
- Networking:
 - autoNet Live View
 - Remote Diagnostics
 - Remote Image Review
 - Remote Management
- Optical X-ray on/off sensor
- Sharp Scroll
- Threat Image Projection (TIP)
- Tropical humidity kit
- Tunnel extensions
- Uninterruptible power supply
- User management
- Variable height OCP mount
- X-ray image viewer software

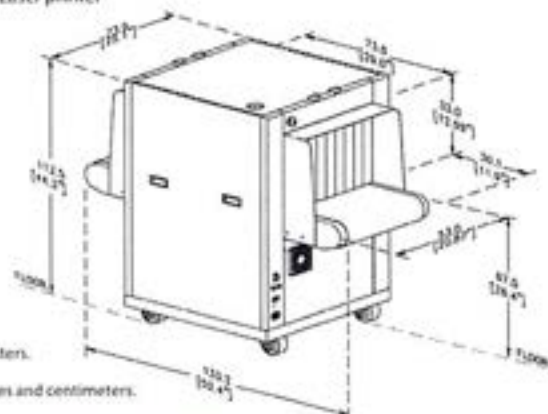

World Headquarters
10A Bloomfield Avenue
Pine Brook, NJ 07058 USA

Tel. +1 973.276.6000
+1 973.276.6161
Fax. +1 973.227.0832

www.autoclear.com

info@autoclear.com

QUALITY CERTIFY

Compliant with US FDA, Chapter I, Department of Health and Human Services, Subchapter J, Radiology of Health, Performance Standards for Imaging Radiation Emitting Products 21 CFR 1020.40 Calibrated X-ray Systems.

ISO 9001:2015 REGISTERED

2015-2019 © Autoclear, CheckClear®, Control Screening®, Dynamis®, HandWand® and Screeners® are among our many registered trademarks. All rights reserved.

500A014 - Spec. Sheet 5333DVS - Rev. E - 10/09/2020

AGENDA
ITEM # 11:
ADMINISTRATOR'S REPORT



OFFICE OF THE JASPER COUNTY ADMINISTRATOR

*Jasper County Clementa C. Pinckney Government Building
358 Third Avenue – Courthouse Square – Post Office Box 1149
Ridgeland, South Carolina 29936 - 843-717-3690 – Fax: 843-726-7800*

James "Jim" Iwanicki, P.E.
Interim County Administrator

jiwanicki@jaspercountysc.gov

Tisha L. Williams
Executive Assistant

twilliams@jaspercountysc.gov

JUNE 1, 2026 - COUNCIL MEETING

ADMINISTRATOR'S REPORT

1. Calendar Year 2026 Special Called Meetings and Workshops:

Updated spreadsheet follows this report.

2. Ms. Burgess staff regularly reconcile bank statements and have recently found several fraudulent charges by people outside Jasper County. They have been working together with Mr. Skinner to address those transactions.
3. Greenbelt – The Low Country Land Trust has applied for \$2 million in 2024 Greenbelt Sales Tax funding to place an easement on the Chelsea Property. Although the Sales Tax Advisory Committee has reviewed the application and scoring criteria. All the elements in the Greenbelt Ordinance are not in place to review and score the application

PROGRESS REPORT

May 11, 2026 – May 26, 2026

1. Discussed and finalized contract terms with Mr. Larson and Nix Construction on the Boat Landing Design Build Project on May 11.
2. Discussed Exit 3 project and funding with Hardeeville on May 11.
3. Staff meeting with all administrator's direct reports on May 11.
4. Attended TC Conduction Gran Opening on May 13.
5. Discussion Fire Service Consolidation with Hardeeville on May 13.
6. Discussed Exit 3 History with and legal counsel Ray Jones on May 13.

7. Attended the Airport Commission Meeting on May 13 which was canceled due to lack of a quorum.
8. Discussion of Airport matters with Mr. Larson and legal counsel on May 11.
9. Called into Port Authority Meeting on May 15.
10. Met with Town of Ridgeland officials on May 15 to discuss operational concerns they had with emergency services.
11. On May 15 met with Ms. Burgess to finalize items for the May 18 Budget Workshop.
12. Council meeting and workshop May 18.
13. Staff meeting with all administrator's direct reports on May 19 to set expectations.
14. Attended the Levy Community Meeting on May 19.
15. Met with Hank Amundson, Executive Director of LCOG on May 21.
16. Met with Heather Rath to discuss her contract with the County
17. Met with Chief Wells to discuss JCFR Issue.
18. Met with Roadway Program Manager of the 1% Sales Tax Team sales tax to provide guidance on several items regarding Argent and US 278 projects.
19. Met with Chief Wells to discuss Hardeeville Joint Services proposal.
20. Staff meeting with all administrator's direct reports on May 26.
21. Met with Ms. Burgess, Chief Wells, and Mr. Flynn to discuss Hardeeville Joint Services proposal on May 26.

County Council
2026 Workshops

Topic	Type of Meeting	With Council Meeting or Stand Alone	Day	Date	Time	Venue
1 Jasper Telfair Development	workshop	w/ council meeting	Monday	1/5/2026	5:30pm	Council Chambers
2 Transfer of Custody - Detention Center	special meeting	stand alone	Monday	1/14/2026	4:00pm	Virtual
3 Jasper County Greenbelt Program	workshop	w/ council meeting	Monday	1/20/2026	5:00pm	Council Chambers
4 Business Items and Financial Retreat	special meeting	stand alone	Monday	1/26/2026	9:30pm	Council Chambers
5 Personnel Matters & AUP	executive session	stand alone	Monday	2/5/2026	2:00pm	Council Chambers
6 Intergovernmental Agreements	executive session	stand alone	Monday	2/9/2026	5:00pm	Hardeeville City Hall
7 Euhaw Overlay District	workshop	stand alone	Monday	3/23/2026	1:00pm	Council Chambers
8 Budget Workshop - Board of Elections	workshop	w/ council meeting	Monday	4/6/2026	4:00pm	Council Chambers
9 Shared Services Town of Ridgeland	executive session	stand alone	Wednesday	4/15/2026	4:00pm	Town of Ridgeland
10 Jasper Telfair PDD and Development Agreement	workshop	w/ council meeting	Monday	4/20/2026	4:00pm	Council Chambers
11 Shared Fire and EMS Services Hardeeville	special meeting	stand alone	Wednesday	5/5/2026	10:00am	Hardeeville City Hall
12 Budget Workshop - Clerk of Court & General Info	workshop	w/ council meeting	Monday	5/18/2026	4:00pm	Council Chambers
13 Shared Hardeeville Services & Budget Workshop	special meeting	stand alone	Wednesday	5/27/2026	10:00am	Council Chambers
14 School System Budget Workshop & Budget Workshop	workshop	w/ council meeting	Monday	6/1/2026	4:00pm	Hardeeville City Hall
15						
16 Joint Meeting re: Economical Development	workshop	TBA	TBA	TBA	TBA	TBA
17						
18						
19						
20						
21						



AGENDA
ITEM # 12:
COUNCILMEMBER COMMENTS